



Part of Absolent Air Care Group

Operation & Maintenance Manual

FILTERHAWK EBM



READ AND SAVE THESE INSTRUCTIONS

Visit our Website for more information on this product



www.diversitech-air.com



www.diversitech.ca

3200 Guenette St, Saint-Laurent, QC H4S 2G5

Tel: 1-800-361-3733 | Fax: 1-514-631-9480 | info@diversitech.ca

Table of Contents

SECTION 1 - SAFETY PRECAUTIONS OF FUME & DUST EXTRACTION/COLLECTION	3
1.1 Symbols	3
1.2 Users responsibility	3
1.3 Fume extraction hazards	3
1.4 Dust collection hazards.....	4
1.5 Safety stickers	4
SECTION 2 - INTRODUCTION	4
SECTION 3 - GENERAL SAFETY WARNINGS	4
3.1 Lockout/Tagout (LOTO)	4
3.2 Electrical safety	4
3.3 Warning labels and safety guards	5
SECTION 4 - GOODS RECEPTION	5
4.1 General delivery information.....	5
4.2 Inspection and Unpacking	5
SECTION 5 - TECHNICAL SPECIFICATIONS	6
SECTION 6 - EBM COMPONENTS AND DIMENSIONS	6
SECTION 7 - INSTALLATION INSTRUCTIONS	8
7.1 Tools and Equipment Required for Installation	8
7.2 Installation steps	8
SECTION 8 - CARTRIDGE FILTER INSTALLATION OR REPLACEMENT	10
SECTION 9 - SYSTEM OPERATION	12
9.1 Filters.....	12
9.2 Cleaning system	12
9.3 Pulse control panel	13
9.4 Recommended Pulse control panel settings	14
9.5 Startup procedure	15
9.6 Shutdown procedure	15
SECTION 10 - ROUTINE INSPECTION & PREVENTIVE MAINTENANCE	16
10.1 Compressed Air System.....	16
10.2 Cartridge Filters.....	16
10.3 Metal Mesh Filters	16
10.4 Metal parts.....	16
10.5 Motor.....	16
10.6 Routine Checking Recommendation.....	17
SECTION 11 - ROUTINE INSPECTION & PREVENTIVE MAINTENANCE	18
SECTION 12 - SPARE PARTS	23
SECTION 13 - WARRANTY	23
Terms and Conditions to Sales Orders	24

SECTION 1 - SAFETY PRECAUTIONS OF FUME & DUST EXTRACTION/COLLECTION



READ
BEFORE
USE

This manual contains specific cautionary statements related to worker safety. To protect yourself and others, read this manual thoroughly and follow as directed before use. Not all hazards of fume & dust control are listed in this manual, and no hazards related to welding, cutting, grinding, painting, deburring or other applications are listed. Consult a qualified safety professional.



DO
NOT
USE

Do not use this equipment:

- To extract smoked or fumes above 180°F/82°C.
- To extract combustibles dust, liquid vapors, or aggressive fumes such as acids.
- If the power cord has been damaged or ground (third prong) removed.
- Without a filter.

1.1 Symbols

This manual uses several symbols to highlight specific hazards. Be familiar with these symbols and when you see them in this manual, read adjoining warning text to avoid the hazard.



WARNING!
DANGER!



**ELECTRIC
SHOCK**



**MOVING
PARTS**



**HOT
PARTS**

1.2 Users responsibility

- Improper use can be hazardous.
- All users must carefully read and understand this instruction manual prior to use
- No objects, such as tools, should be placed on the machine.
- When moving machine, care should be taken to ensure the users feet remain clear of the wheels.
- Motor should not contact any objects, and all motor repairs should be performed while the power switch is off and the power source is disconnected. Operator should not touch motor during use.
- Blower assembly should not contact any objects, and all blower repairs should be performed while the power switch is off and the power source is disconnected. Operator should not touch blower during use.
- For maintenance of any and all components, power switch must be off and the power source disconnected
- It is your responsibility to follow all applicable ANSI, OSHA, UL, CSA, National & Local Fire Codes, and other regulatory guidelines covering the safe use and installation of equipment that extracts fumes, collects dusts, and exhausts filtered air either indoors or outdoors.
- Before use, inspect the unit for damage and verify it is working properly.
- Only qualified persons should install, operate, maintain, or repair this unit.
- Do not modify or repair the unit with parts or accessories not supplied by the manufacturer.

1.3 Fume extraction hazards

- Breathing smoke, fumes, or dusts produced in applications such as welding, cutting, grinding, painting, deburring are hazardous to user's health. Proper ventilation or use of well maintained fume extraction and/or dust collection equipment helps the user avoid these hazards.
- Breathable contaminants may not be visible or have an odor.
- Stop operation and leave the area immediately if 1) breathing becomes difficult, 2) experience dizziness, impaired vision, 4) or eye/nose/mouth irritation.

1.4 Dust collection hazards

- Dusts from many metalwork, welding, cutting, grinding, painting, or deburring applications can be combustible.
- Do not use or install equipment where any potential for combustible fumes or dusts are present, until a qualified person has indicated it is safe to do so.
- Never use or install equipment where the potential for combustible fumes or dusts are present without a fire/explosion protection system.
- If you are unsure if the product you purchased is correct for your application, call Diversitech at 1-855-976-5190

1.5 Safety stickers

- This machine is equipped with safety stickers to remind operators of the inherent dangers during use and maintenance.
- The stickers are only reminders, and all safety precautions contained in this manual must be well understood and adhered to by all users.

SECTION 2 - INTRODUCTION

This manual explains how to receive, install, operate, and maintain your Diversitech's EBM. All personnel involved in handling or servicing the unit must read and follow this manual to ensure safe, compliant, and efficient operation. Failure to follow these instructions may result in injury, equipment damage, or voided warranty.

The EBM is designed to continuously remove smoke, fumes, and dust, transforming any workspace into a clean air zone. The system uses ambient style air cleaning technology to pull dirty air through high efficiency filters and recirculates it as clean, fresh air - no ductwork required.

Each unit is built from high-quality materials, assembled by trained personnel, and tested before shipment.

While this guide covers standard procedures, certain tasks - such as electrical wiring, mechanical assembly, and heavy equipment operation - must be performed by qualified personnel in accordance with local, state/provincial, and federal regulations

SECTION 3 - GENERAL SAFETY WARNINGS

The EBM is industrial equipment that may involve heavy lifting, high-speed rotating components, electrical power, and compressed air. Safe operation depends on proper planning, training, and adherence to all applicable health, safety, and environmental (HSE) regulations.

All personnel involved in receiving, installing, operating, or maintaining the EBM must be trained, authorized, and familiar with this manual. Typical tasks may involve riggers, electricians, installers, operators, and maintenance staff. The site supervisor must ensure that all workers understand the potential hazards and follow the required safety precautions.

3.1 Lockout/Tagout (LOTO)

The EBM maintenance or service must be done in accordance with OSHA 29 CFR 1910.147 ("Control of Hazardous Energy") or equivalent local regulations.

- Before servicing, cleaning, replacing Cartridge filter or inspecting the unit, isolate all energy sources including electrical, pneumatic, and any stored energy in moving parts.
- Apply lockout and tagout devices to prevent accidental start-up.
- Verify zero energy before beginning work.

3.2 Electrical safety

- Electrical work must be performed only by qualified and licensed electricians.
- Disconnect and lock out the main power supply before performing any work inside electrical enclosures or wiring.
- Follow NFPA 70E (or equivalent) arc-flash and shock protection requirements, including the use of insulated tools and arc-rated Personal Protective Equipment.
- Keep electrical panels closed and secured during normal operation.

3.3 Warning labels and safety guards

- Do not remove, cover, or alter any warning decals. Replace them if they are missing or unreadable.
- Ensure all safety guards and covers are installed and secure before operating the equipment.
- Never bypass safety interlocks or switches.

SECTION 4 - GOODS RECEPTION

4.1 General delivery information

- EBM unit can be shipped in multiple containers, depending on the configuration.
- Each unit is placed on a wooden pallet and securely wrapped in plastic.
- Exercise caution when handling units delivered in an upright position, as they may tip over.

4.2 Inspection and Unpacking

Upon delivery, inspect the shipment before removing it from the carrier's vehicle.

- Check the packaging for visible signs of damage, including dents, punctures, or tipping.
- Document any damage with photographs and written notes on the bill of lading prior to accepting the shipment.
- Notify Diversitech immediately of any visible damage or missing components.

After acceptance:

- Carefully remove all packaging materials.
- Verify that the unit and all ordered accessories are present.
- Inspect the equipment for any concealed damage that may have occurred during transport.

Shipping Damage Responsibility:

- If Diversitech arranged the shipment, the customer must notify Diversitech of any damage or shortages. Diversitech will coordinate directly with the carrier to resolve the issue.
- If the shipment was arranged by the customer or a third party, the owner is responsible for filing any damage or loss claims directly with the carrier.

SECTION 5 - TECHNICAL SPECIFICATIONS

Model	Controls	Nominal Airflow (CFM)	Motor			Cartridges / Filters			
			(H.P)	Volts	(p/hz)	Qty.	Area (Sq. Ft.)	Size	Type
EBM Standard	Controller with ON/OFF	8,000	15	230/ 460/ 575	3/60	6	1,890	36" height	MERV 15 Nanofiber
EBM PRO	VFD Controller with variable speed	3,000 - 8,000							

SECTION 6 - EBM COMPONENTS AND DIMENSIONS

Unit: Inch

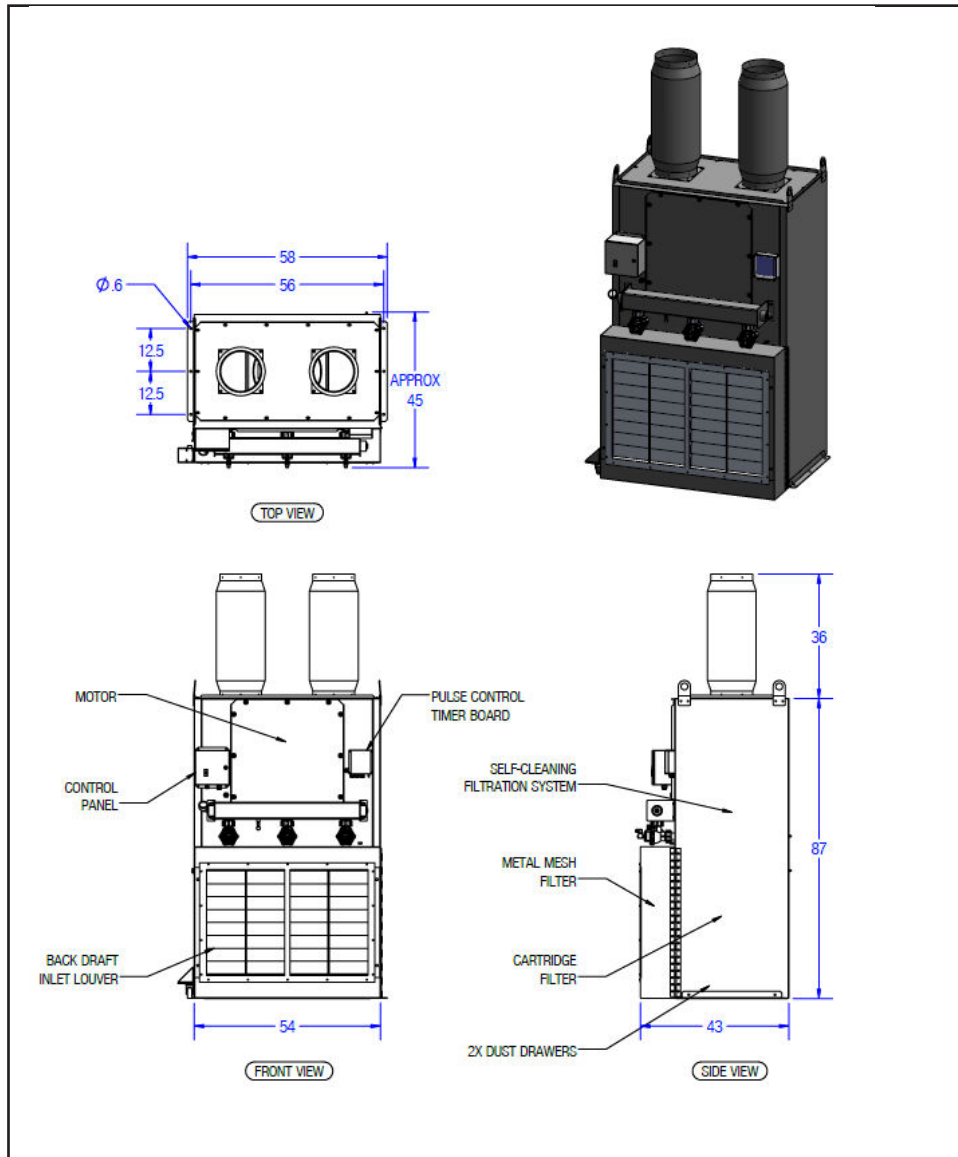

Exhaust Configuration Options:

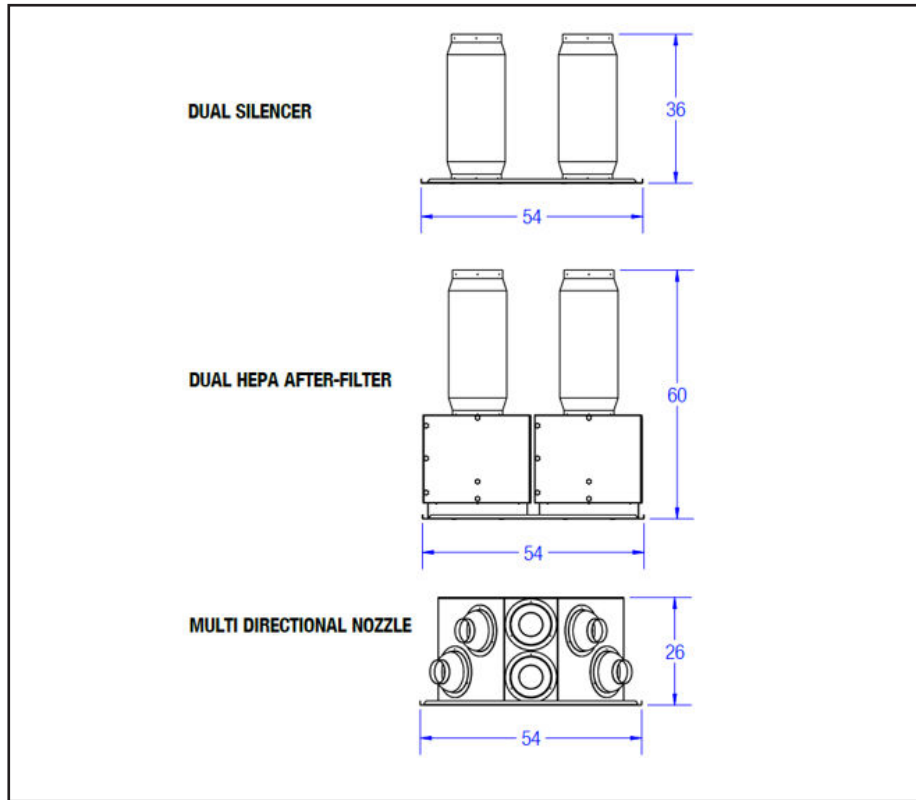

Door Configuration Options:

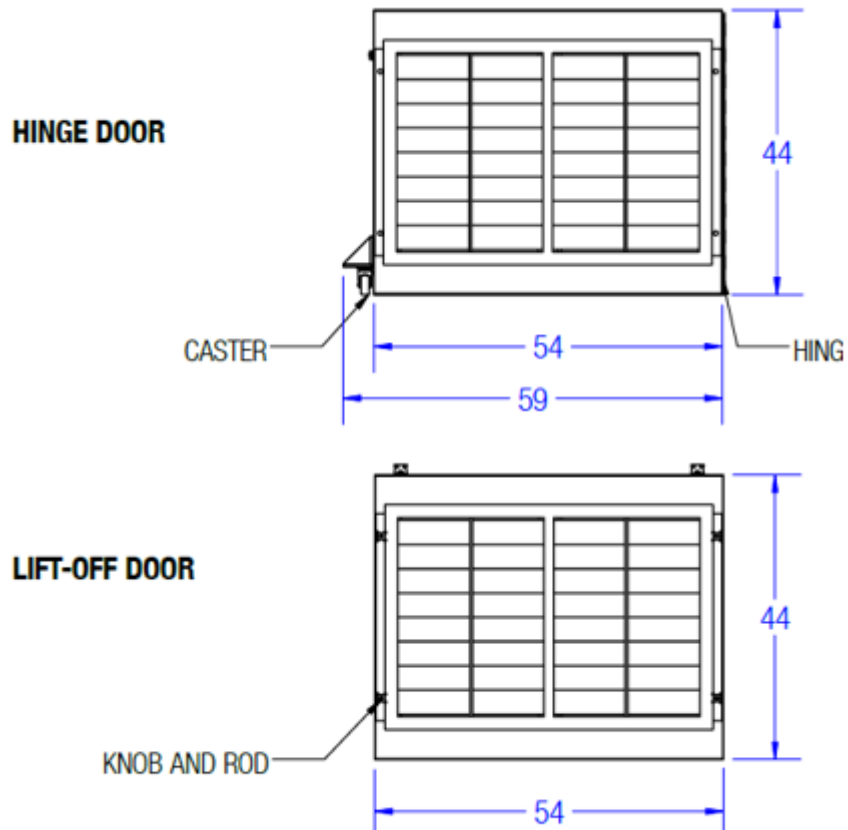

SECTION 7 - INSTALLATION INSTRUCTIONS

7.1 Tools and Equipment Required for Installation

The following tools and equipment are needed to complete the installation:

- SAE socket wrench set
- Screwdriver sets
- Impact wrench
- Hammer drill
- Floor anchors
- Wire cutters
- Wire nuts
- Electrical tape
- Electrical conduit
- 1/4" NPT compressed air connection
- Thread sealant
- Heavy machinery (forklift or crane)
- Level

7.2 Installation steps

1. If your unit is equipped with a dual Silencer, install it as follows:

- Place the silencers onto the collars on top of the EBM unit.

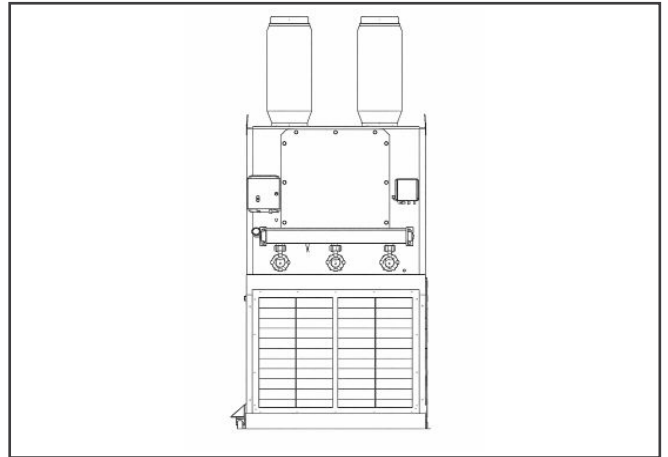

2. If your unit is equipped with a dual Hepa after-filter, install it as follows:

- Using proper lifting equipment (forklift or crane), carefully raise one HEPA filter box at a time.
- Position the HEPA box on top of the cabinet assembly.
- Secure it in place using the hardware supplied by Diversitech.
- Repeat the process for the second HEPA box.
- Place the silencers onto the collars on top of the HEPA boxes.

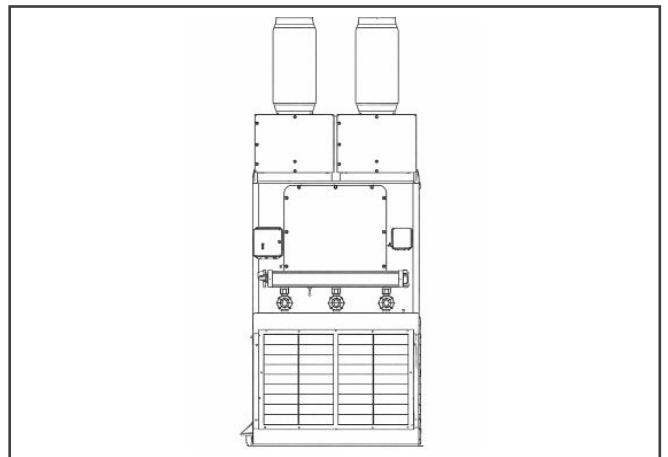

3. If your unit is equipped with a multi-directional nozzle, install it as follows:

- Using proper lifting equipment (forklift or crane), carefully raise the exhaust.
- Position it on top of the cabinet assembly.
- Secure it in place with the 1/4"-25 bolts and nuts supplied by Diversitech.

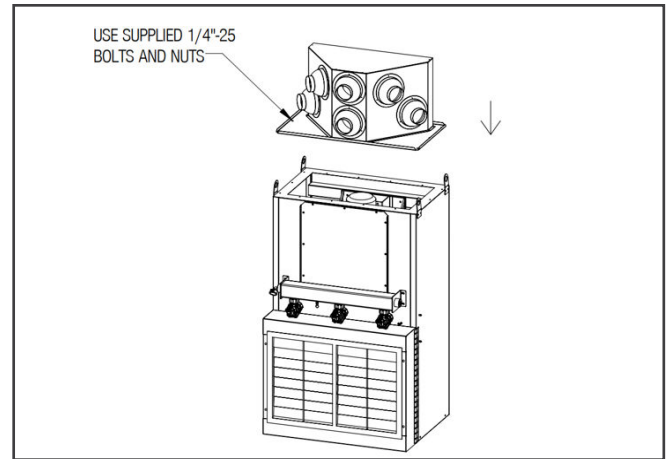

4. Install Air Supply:

- The air supply line to the compressed air reservoir must include water, oil, and particulate filtration. Moisture and especially oil in the air supply will reduce the effectiveness of the reverse jet pulse cleaning by contaminating the cartridge filters, increasing differential pressure, reducing airflow, and causing premature filter replacement.
- For optimal performance and protection, we recommend including the following components in the compressed air system:
 - ◇ Manual shut-off valve
 - ◇ Filter or separator
 - ◇ Air pressure regulator
 - ◇ Pressure gauge
- Prior to the final connection of the air line to the collector, purge the line to remove any debris that could damage the valves or block the blow pipe nozzles. Then connect the compressed air supply, ensuring a minimum pressure of 80 PSI and a maximum pressure of 100 PSI.

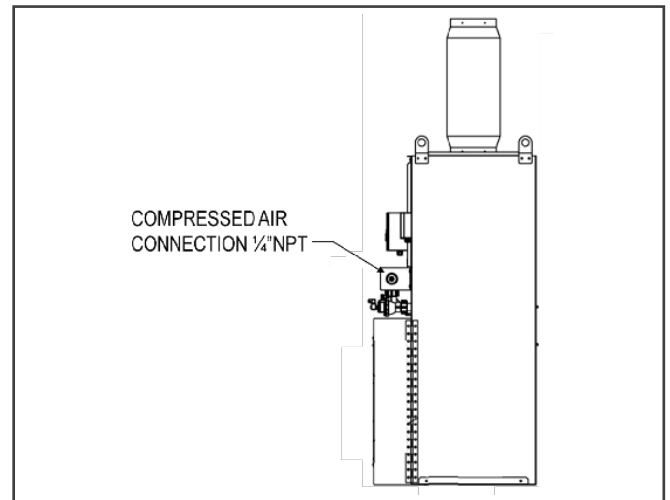

5. Electrical connections:

- All electrical connections and wiring must comply with local, state, and national codes. Power connections must be made by a certified electrician.
- The blower is designed to rotate clockwise when viewed from the motor side (top of the blower). If the blower runs in reverse, airflow will be reduced to approximately 50% of the design volume, and excessive noise will occur. After wiring the motor, check rotation by briefly energizing the blower motor ("jogging"). If rotation is incorrect, reverse the wiring as needed.

SECTION 8 - CARTRIDGE FILTER INSTALLATION OR REPLACEMENT

Multiple option types of replacement filters are available.

Contact Diversitech for assistance in selecting the most suitable replacement filters for your application.

1. **Disconnect all power and air sources.** Shut off electrical power to the fan and control box and disconnect the compressed air supply. **Bleed all air from the air tank.**
2. **For replacements,** keep pulsing the collector for 20 more minutes after the fan shuts down; this will make the cartridge filters lighter and more convenient to move.
3. **Removing Old Cartridges:**
 - I. Open the unit's front access doors completely.
 - II. Release the lock levers: The filter is secured by lock levers. Pull both cam lock levers toward you to release the pressure holding the filter in its housing. At this point, the filter guide bars should drop down.



- IV. Pull the filter: Once the lock lever is disengaged, grasp the top of the filter and pull it straight out of the dust collector to remove it.



- V. Remove dust from the tube sheet surface where the filter gasket contacts.

4. Installing New Cartridges:

- I. Carefully unpack a new cartridge, avoiding any damage to the filter media. Ensure the clamp bars are fully open and won't obstruct the installation.
- II. Hold the new cartridge only by its top metal pan. This prevents damage to the delicate filter pleats.
- III. Align the cartridge with the opening in the dust collector. Using the metal pan, slide the filter straight along the filter guide bars into place. Do not push on the filter media itself, as this can crush the pleats and reduce the filter's effectiveness.
- IV. Push the cartridge in firmly until it's fully seated inside the housing. Push it just far enough to leave room for the next cartridge.
- V. Repeat this process inserting one cartridge at a time until the entire row is filled.

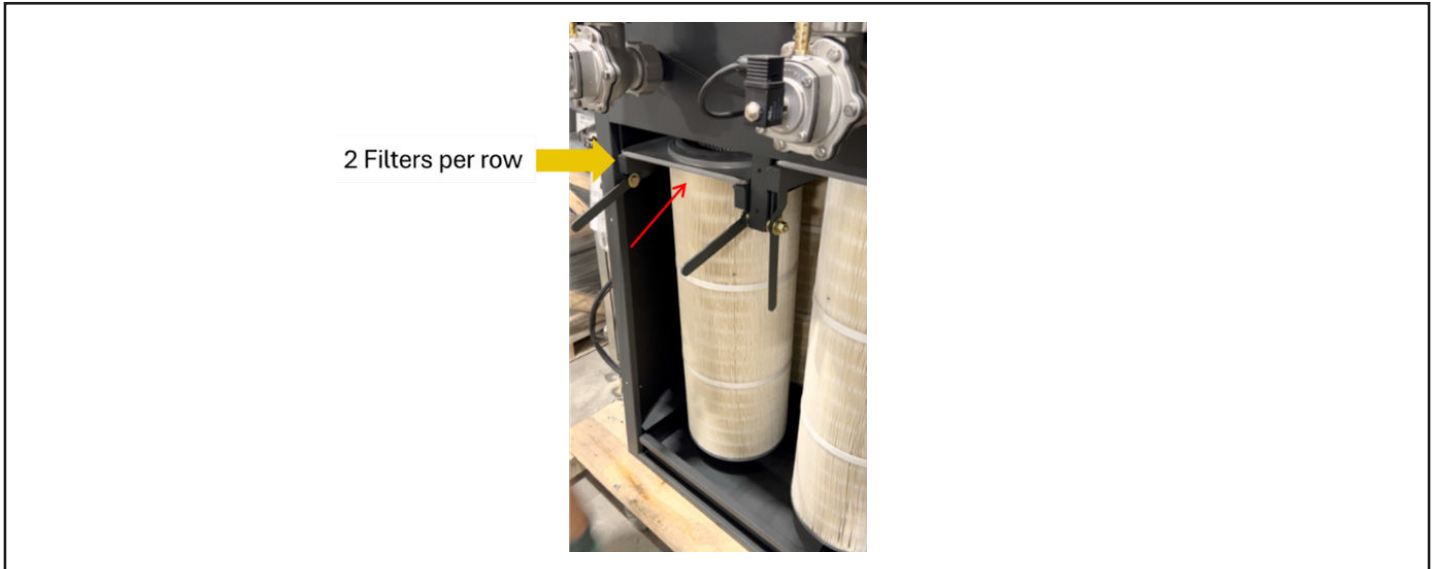

5. Sealing the New Cartridges:

- I. Engage the lock lever: Push both cam lock levers away from you into the locked position, pressing down firmly. The filter guide bars should rise.
- II. Verify that the lock lever is fully engaged and the filter is held tightly. This ensures an airtight seal, preventing any dust from bypassing the filter.
- III. Repeat these steps for all remaining cartridge rows.

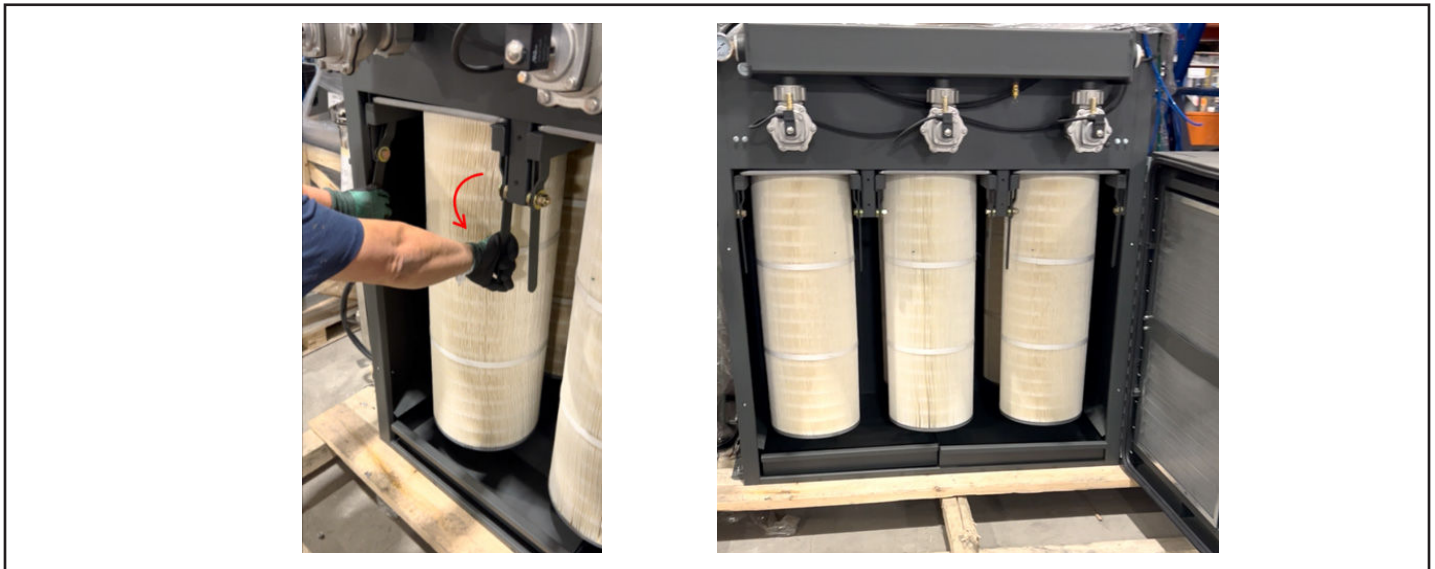

SECTION 9 - SYSTEM OPERATION



9.1 Filters

For the filters to operate effectively, a layer of dust - known as the 'dust cake' - must accumulate on their surface. While this buildup enhances filtration efficiency, it also naturally reduces airflow over time.

Filters must be cleaned periodically, requiring a balance between dust cake accumulation, cleaning cycles, and airflow reduction.

9.2 Cleaning system

The cartridge filters are cleaned automatically during operation, so machine shutdown is not required.

The cleaning cycle reverses airflow through the filter media in pulses, dislodging accumulated dust. Filters are cleaned sequentially, allowing the remaining filters to continue purifying the air without interruption.

- **Cleaning system components:**

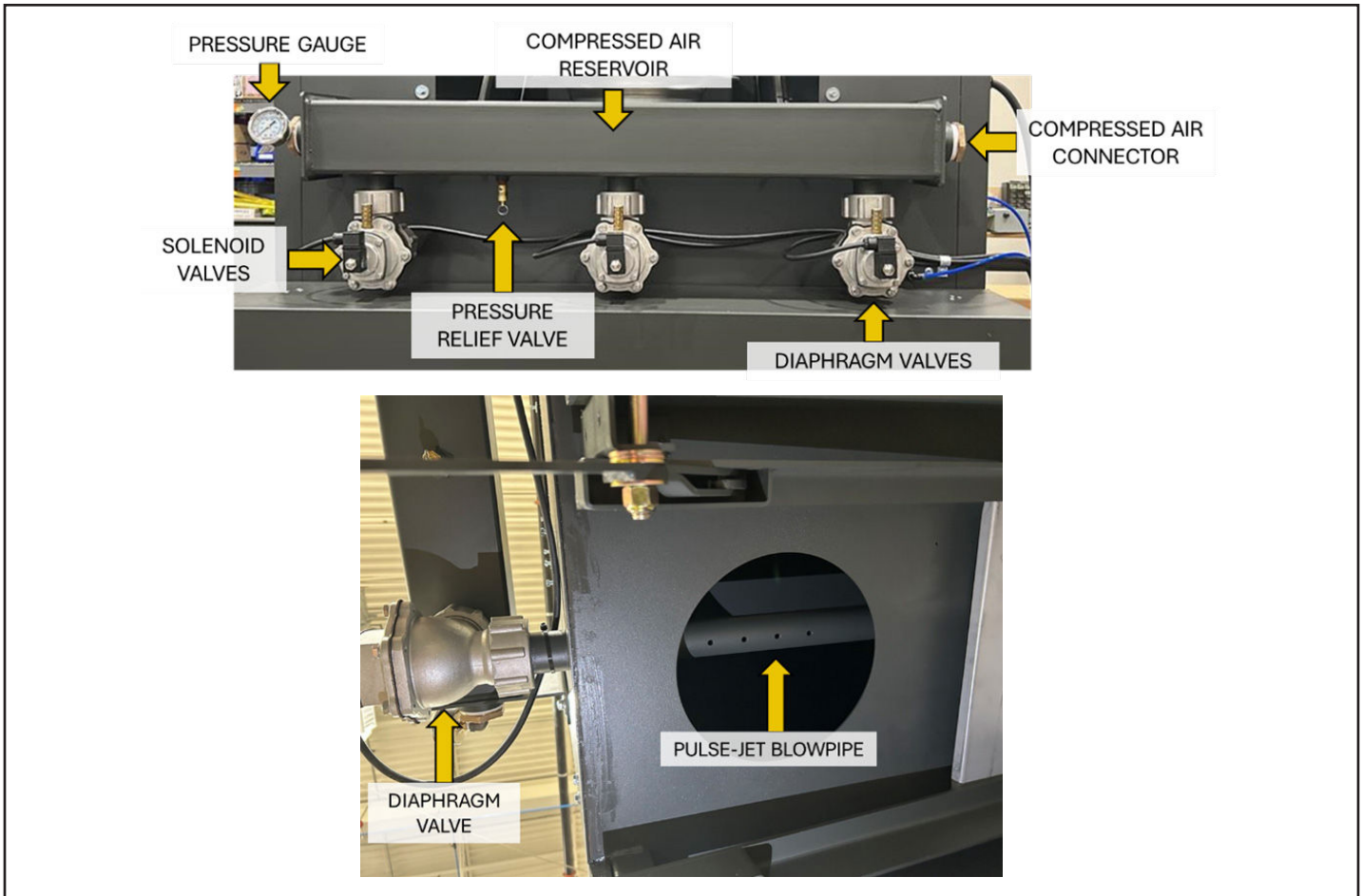

- **Operation:**

1. Connect a supply of clean, dry compressed air (80–100 PSI) to the compressed air reservoir.
2. Each solenoid valve controls one diaphragm valve.
3. Each diaphragm valve operates one pulse-jet blowpipe.
4. Each pulse-jet blowpipe is positioned directly above two cartridge filters.
5. When the pulse control energizes the solenoid, air pressure is released through the exhaust port.
6. This releases pressure in the outer chamber of the diaphragm valve.
7. The resulting pressure differential causes the diaphragm valve to open.
8. Compressed air from the reservoir is discharged into the pulse-jet blowpipe.
9. The pulse air accelerates through a reduced-diameter opening.
10. Air wave travels down the full internal length of the cartridge, dislodging dust accumulated on the external surface of the filter.
11. Each row of cartridge filters is pulsed separately which reduces internal static pressure extending filter life and overall dust collector performance.

9.3 Pulse control panel

The pulse control panel is connected either to the SDS Panel (Starter/Disconnect/Selector or Soft Starter Panel).

Diversitech uses the E2T series pulse control panel, which features a front display with four round buttons for navigation, control, and display activation.



Navigation instructions:

- Press **SET** to open or close the programming menu.
- Use **+** and **-** to:
 - ◊ Select functions
 - ◊ Increase/decrease values
 - ◊ View the total hour counter (+)
 - ◊ View the maintenance counter (-)
- Press **OK** to confirm entries and reset alarms.

To activate the manual solenoid test, select function **F06** from the menu.

For more details, refer to the ECONOMIZER SERIES E2T User Manual by Turbo.

9.4 Recommended Pulse control panel settings

Diversitech's EBM comes with the following recommended settings pre-programmed:

- **Pulse Duration: 200 milliseconds.** This corresponds to the solenoid activation time, which is the duration the valve stays open.
- **Pulse Pause Time between Solenoid Valves: 20 seconds.** The pulse frequency determines how often the system cleans the cartridges with a blast of compressed air.
 - ◊ Higher pulse frequency (a longer interval between pulses) reduces compressed air consumption. This is ideal for applications with light dust loads.
 - ◊ Lower pulse frequency (a shorter interval between pulses) increases compressed air consumption. This may be necessary for applications with heavy dust loads or dust that doesn't easily release from the cartridges.
- **Differential Pressure (dP) Settings:** These settings control when the cleaning system starts and stops based on the pressure difference across the filters.
 - ◊ Cycle Start - High dP Set Point: 3.2 in.wg. This value triggers the cleaning system to start.
 - ◊ Cycle Stop - Low dP Set Point: 1.6 in.wg. This value stops the cleaning system once the pressure has dropped to this level.
 - ◊ Max dP Alarm: 6 in.wg. This alarm protects the cartridges from damage caused by high differential pressure. A filter clog is indicated if the high dP condition persists for more than 20 seconds.

For assistance with custom settings, please contact your Diversitech representative.

Mode	Description	Setting
F1	Mode of operation	2 - Automatic with forced cycle
F2	Pulse Duration	0.2 Second
F3	Pulse Pause Time between Solenoid Valves (Fan ON)	20 Seconds
F4	Number of valves	It depends on the unit
F5	Output voltage	115 Vac
F6	Manual activation of the solenoid valves	Press SET to activate the set output
F7	Zero dP threshold	0.00 inch WC.
F8	Cycle Start - High DP Set Point	3.2 inch WC.
F9	Cycle Stop - Low DP Set Point	1.6 inch WC.
F10	Max dP Alarm	6 inch WC.
F11	Fan OFF Detection Method: The system identifies the fan status as OFF using either of the following methods: 0 – via motor starter contacts; 1 – via differential pressure (dP) signal	1
F12	dP setting for fan OFF detection (active if F11 = 1)	0.5 inch WC.
F13	Number of cycles the system executes in pulse mode following shutdown	5
F14	Post cleaning mode pausetime between solenoid valves (Fan OFF)	10 Seconds
F15	Maintenance frequency expressed in tens of hours	100
F16	Maintenance deadline alarm enable	0 (Disabled)

Mode	Description	Setting
F17	Maintenance hour counter reset	0 (Disabled)
F18	Precoating function enabling	0 (Disabled)
F19	dP threshold for precoating function (pulsing is suspended until this level is reached)	8 inch WC.
F20	Enabling Minimum dP alarm function if detected for longer than 60 seconds	0 (Disabled)
F21	Minimum dP alarm threshold	0.8 inch WC.
F22	Forced cleaning cycle units, only operates if the mode F1 = 2. 0 for Minutes and 1 for Hours	0 (Minutes)
F23	Setting time interval for Forced cleaning cycle in relation to the choice of mode F22.	10
F24	Exclusion of valve in short circuit 0 – the valve in short is tested at each cycle 1 – when the valve is in short is excluded from the cycle and is not rechecked	0

9.5 Startup procedure

1. Perform a System Check before starting the unit:
 - Inspect compressed air connections.
 - Check all electrical wiring for proper connections.
 - Ensure all filters are correctly installed and firmly secured.
 - Ensure the collector door is properly closed and latched.
 - Ensure that the blast gate is fully open.
2. If your unit is equipped with a multi-directional nozzle, position the nozzles to ensure optimal air circulation, directing clean air toward adjacent areas or units to maximize coverage and maintain proper airflow throughout the workspace.
3. Supply compressed air and electrical power to the collector.
4. Manually activate the cleaning system. Check the adequacy of air supply by assuring no less than 35% drop in pressure during pulse.
5. Verify that the fan rotates in the correct direction. Rotation must be clockwise when viewed "OVER THE MOTOR" from the discharge side. If the rotation is correct, start the motor.
6. Start the dust collector by pressing the START / I button on the control panel.

9.6 Shutdown procedure

1. Stop the dust-generating operation.
2. Turn off the fan.
3. The digital reverse pulse cleaning systems are equipped with an "Off Line Cleaning" feature which activates the reverse jet pulse cleaning. This element will clean the filter cartridges while the unit is off line, for a preset number of pulses. Once the cleaning cycle is complete the collector is ready to be energized when needed.

SECTION 10 - ROUTINE INSPECTION & PREVENTIVE MAINTENANCE

Regular maintenance of the unit is key to achieving consistent performance and a long service life. By keeping track of pressure drop, airflow, and cleaning schedules, any required maintenance can be performed promptly. This helps minimize wear, avoid unexpected downtime, and prolong the life of both the filter cartridges and other system components.

10.1 Compressed Air System

Regular inspection of the compressed air system is essential, as it directly affects filter cleaning and overall performance. Check the following components:

- Shut-off valve: Confirm it opens and closes properly.
- Pressure level: Ensure it reaches the recommended range.
- Solenoid and Diaphragm valves: Check for leaks and proper operation.
- Fittings: Verify all clamps and connections are secure, with no air escaping.
- Compressed air reservoir: Inspect for corrosion, cracks, or other damage. Periodically open the valve beneath the tank to drain accumulated moisture.
- Pulse Jet blowpipe: Inspect for clogs, blockages or any damage that could reduce cleaning efficiency.

Additionally, inspect the entire compressed air system for leaks to maintain optimal performance.

10.2 Cartridge Filters

Replace filters if any of the following apply:

- Differential pressure stays above 6 in. w.g. after cleaning.
- In service over 2 years.
- Damaged by moisture, heat, or other conditions.

10.3 Metal Mesh Filters

The metal mesh filters should periodically be inspected and cleaned. Any buildup of material in the filters can lead to fires.

To examine:

- Remove the access panel
- Pull out both metal mesh filters
- Wash with soap and water, and air dry
- Replace both metal mesh filters
- Replace the access panel

10.4 Metal parts

Treat the inner and outer surfaces of your StromTower like any painted metal. Regularly inspect for corrosion, scratches, or other surface damage.

10.5 Motor

To ensure reliable operation and extend the life of your dust collector motor, perform the following preventive maintenance regularly.

- Check for dust, debris, corrosion, or loose bolts.
- Look for signs of overheating such as discoloration or unusual smells.
- Examine shafts and couplings for wear or damage.
- Run the motor and listen for unusual noises.

10.6 Routine Checking Recommendation

Daily:

- Monitor control indicators for any alarms.
- Verify that the timer is sequencing correctly.
- Ensure valves are operating properly and in the correct sequence.
- Verify compressed air pressure is within the required range.
- Check the compressed air system for leaks (causing low pressure) or blockages, and repair as needed.

Weekly:

- Inspect metal mesh filters. Clean if necessary.
- Check the empty drawer for proper operation.

Monthly:

- Check filter cartridges for leaks and proper fastening; repair or replace as necessary.
- Inspect the motor, fan or blower, and dust collector metal parts for signs of corrosion.
- Clean dust from the motor housing, vents, and cooling fins to prevent overheating.
- Check for dust or material buildup in the fan or blower.
- Ensure proper alignment of the motor with the fan or blower.
- Inspect and lubricate components as needed.
- Examine hoses and clamps for wear or damage.
- Inspect access doors and seals for leaks or deterioration.
- Check air lines and fittings for leaks.
- Verify electrical connections for the motor and pulse board panel.
- Check for loose bolts in the structure.
- Inspect the louvered inlet for any signs of damage.

SECTION 11 - ROUTINE INSPECTION & PREVENTIVE MAINTENANCE

Low Air Pressure – Causes & Solutions

Cause	Solution
Regulator set to low	Adjust regulator to maintain 80–100 psi compressed air
	Install a regulator or gauge on the air header, if possible
Supply line too small	Ensure compressed air supply line is sized correctly
Compressor too small (for total plan requirements)	Perform a compressed air audit
	Reduce consumption where possible
	Repair leaks and eliminate unnecessary air loss
	Upgrade to a larger compressor, or add an additional compressor to the system
Excessive compressed air consumption	Inspect for leaks in the compressed air system and repair as needed
	Ensure the air header drain valve is closed
	Check that the diaphragm is not stuck in the open position
Restrictions in compressed air piping	Verify compressed air line is clean and free of obstructions
	Ensure hoses to the air header are free of kinks
	Check all valves in the line and confirm they are fully open

High pressure drop – Causes & Solutions

Cause	Solution
Cleaning mechanism not properly adjusted	Increase cleaning frequency
	Perform shutdown for PCC (Pulse cleaning cycle)
	Inspect diaphragms and solenoids; repair or replace as needed
	Check Pulse control panel performance; adjust or repair if required
	Verify compressed air supply is within 80–100 psi
Pulse control panel failure	Consult the Pulse control panel manual
	Verify controller is operational
	Check that power connections are correct and secure
	Confirm the timer cycles through all contact points properly
	Check output on all terminals
Pulse Valve failure	Inspect wiring between the controller and solenoid valves
	Check tubing between solenoid valves and diaphragms
	Inspect diaphragms; repair or replace if needed
	Inspect solenoid valves; repair or replace if required
Blinding of Filter Media	Compare designed airflow to actual airflow and adjust dampers accordingly
	Change filter media type (consult Diversitech Technical Services)
	Perform off-line cleaning
	Increase cleaning frequency (manual or automated)

Cause	Solution
End of Cartridge service life	Replace cartridges
Improper start up of collector	Restart the collector following the procedure in the manual.
Moisture in collector	Keep the cleaning system running for 20 minutes after process shutdown
	Preheat unit before operation
Temperature too high	Introduce dilution air to reduce temperature in the collector
	Install media rated for higher temperatures if required

Poor Airflow – Causes & Solutions

Cause	Solution
Fan malfunction	Correct motor wiring if wheel rotation is reversed
	Replace fan wheel if damaged
	Correct wheel orientation if mounted backwards
	Replace motor if operating temperature is too high
	Repair or replace bent shaft
	Clean fan to remove dust or dirt buildup
	Lubricate, repair, or replace worn bearings
	Inspect for faulty wiring or shorts; repair as needed
Motor overloads	Reduce motor speed if set too high
	Correct wheel orientation if reversed
	Repair or replace bent shaft
	Realign motor and housing if misaligned
	Repair and realign housing if wheel binds
	Lubricate, repair, or replace worn bearings
	Replace motor if temperature is excessive
	Clean fan if buildup of dirt/dust is present
	Repair or rewire if electrical short is found
	Replace defective motor
Plugged cartridges	Replace cartridges if service life has ended
	Inspect and clean pulsing mechanisms
	Increase compressed air pressure or volume
	Eliminate moisture from collector
	Inspect and repair pulse control panel
	Increase media surface area or switch to different media type
Air leaks in the collection system	Replace missing screws, bolts, gaskets, or caulk
	Seal holes or punctures in the system
Improper duct system design	Perform system balance to identify issues
	Review duct design
	Change hood type to improve capture efficiency
	Consult a ductwork installer

Poor efficiency – Causes & Solutions

Cause	Solution
End of cartridge service life	Replace cartridges
Insufficient filter cake	Allow time for dust cake to build (may take several weeks)
	Reduce cleaning frequency
	Switch to different filter media or increase surface area
Incorrect filter media	Install cartridges with media designed for the application
	Check and adjust controller programming
Excessive cleaning cycle	Replace cartridges
Leaking of cartridges	Inspect for punctures
	Inspect/replace gaskets and clean tube sheet for sealing
	Upgrade to different media or increase cartridge area
	Inspect for abrasion damage
Excessive temperature	Use high-temperature-rated filter media
Leaking gaskets	Verify cartridges are correctly seated to prevent ramping
	Ensure the locking mechanism is fully closed
	Remove cartridges and clean the tube sheet for proper sealing
	Replace cartridges if necessary
	If the support bars are bent, replace them

Controller Failure – Causes & Solutions

Cause	Solution
Lack of power	Check the control ON/OFF switch and turn it on
	Verify power is supplied to the board; correct if necessary
	Confirm supplied power matches board requirements
	Ensure all breakers and switches are in the ON position
	Inspect and replace fuses if necessary
	Replace the control board if the issue persists
Fuse blown	Replace the fuse
	Replace the control board if the problem continues
Improper wiring	Verify the timer indexes through all contact points
	Check output on all terminals.
	Inspect wiring between controller and solenoid valves; repair if necessary.
	Verify power connections to the board.
	Consult the Pulse Control Panel manufacturer’s manual for detailed guidance

Controller Failure – Causes & Solutions

Cause	Solution
Improper programming	Verify the correct number of terminals are wired into the control board
	Confirm High and Low setpoints are correctly programmed; adjust as needed
	Consult the Pulse Control Panel manufacturer's manual for detailed guidance
Defective control board	Replace the board
Moisture or contamination in control box	Ensure the controller enclosure is fully closed
	Verify the NEMA rating of the housing; upgrade if necessary
Vibrations causing failure	Remote mount the controller away from vibration sources

Controller Failure – Causes & Solutions

Cause	Solution
Normal noise level of fan operation	Check motor alignment and correct any misalignment that may cause humming or vibration
	Balance the fan wheel if it is slightly off-balance to reduce vibration noise
	Install vibration isolators or pads under the collector or fan to absorb vibrations
Fan housing vibrating	Inspect for damaged fan wheels; replace or repair as needed
	Inspect housing for damage; replace or repair if necessary
	Check for broken or loose bolts or screws; replace or tighten as needed
	Ensure foundation and supports are stable
	Remove any material buildup in the wheel or housing; clean thoroughly
	Verify motor load and correct any overload conditions
Bad fan bearings	Lubricate or replace bearings (for specific motor types)
Constant "hissing" sound	Check for compressed air leaks or disconnected lines
	Inspect and repair stuck diaphragm valves
Electric "humming" sound	Check incoming phase line for missing voltage
	Replace defective starting relay or motor starter

Dust Bridging in Drawer – Causes & Solutions

Cause	Solution
Dust Stored in drawer	Continuously remove dust
Moisture in collector	Ensure only dry compressed air is used; install an air dryer
	Preheat the collector before operation
	Purge collector of high-humidity process air after shutdown
	Inspect and repair leaks in collector
	Prevent moisture carryover from the process

Media Failure – Causes & Solutions

Cause	Solution
End of cartridge service life	Replace cartridges
High pressure drop	Refer to sections on High Pressure Drop
Moisture / Water Present	Refer to sections on Moisture in Collector
Temperature too high	Install alternate media that can tolerate higher temperatures
Application too abrasive	Reduce inlet air velocity; adjust fan
	Install cartridges made of more durable media
Conveying velocity too great	Reduce airflow; adjust fan as needed
	Minimize excess airflow with proper ducting
	Change media area or media type
	Perform off-line cleaning
Compressed air too high during pulsing	Regulate compressed air to 80–100 psi

SECTION 12 - SPARE PARTS

Item description	Diversitech PN	Sell Description
Filter Cartridge Nanofiber Tight Pleat	10003014	36 Nanotech XV Cartridge Filter, 315 sqft, MERV 15, EBM/FH series
Filter Cartridge Nanofiber Wide Pleat	10003016	36 Wide-Pleat Nanotech XV Cartridge Filter, 210 sqft, MERV 15, EBM/FH series
Replacement Hepa Filter	10003043	Hepa Filter, Metal Frame 24 x 24 x 11.5
Replacement 10.0HP TEFC [230/460V/3/60HZ] motor only	10001836	10.0HP TEFC Motor [230/460/3/60]
Replacement 10.0HP TEFC [575V/3/60HZ] motor only	10001842	10.0HP TEFC Motor [575/3/60]
Replacement 15.0HP TEFC [230/460V/3/60HZ] motor only	10001846	15.0HP TEFC Motor [230/460/3/60]
Replacement 15.0HP TEFC [575V/3/60HZ] motor only	10001848	15.0HP TEFC Motor [575/3/60]
Solenoid valve & Diaphragm valve	10005200	Intergrated Pulse Valve Compression Fitting 1.5
Door assembly Lift-Off	10007007	Lift-Off Door for Filter Access. FH-EBM6
Door assembly hinged	10007006	Hinge Door for Filter Access. FH-EBM6
Door metal mesh	10000415	Set of Two Metal Mesh Prefilters. FH-EBM6
Louver	10007005	Back Draft Inlet Louvers. FH-EBM6
Pulse Control Timer Board	10020492	Pulse Control Timer Board, 4 Position
Blower wheel 10HP replacement	10011835	Blower Wheel. Aluminum, .DPrime 400
Cone 10HP replacement	10009510	Cone. Aluminum 400
Blower wheel 15HP replacement	10011833	Blower Wheel. Aluminum, .DPrime 450
Cone 15HP replacement	10009511	Cone. Aluminum 450
Replacement Silencer (Muffler)	10002211	12 dia x 36 Duct Muffler

SECTION 13 - WARRANTY

Diversitech warrants its products for 2 years from the date of purchase against defects in material, workmanship, or construction, provided the product remains in its original form and is serviced or maintained using only original Diversitech parts and consumables. Any modifications, additions, or use of non-original parts will void this warranty.

During the warranty period, Diversitech will, at its discretion, repair or replace any defective parts. This warranty is limited to replacement parts only and does not cover personal injury, property damage, normal wear, or issues caused by improper installation, inadequate maintenance, misuse, misapplication, operation beyond rated capacities, or any customer modifications.

Terms and Conditions to Sales Orders

1. INTERPRETATION

- 1.1. All references to “we”, “us” or “our” herein mean Diversitech Equipment and Sales (1984) Ltd.
- 1.2. All references to “you” or “your” herein mean:
 - (a) the “Customer” referred to herein and in the Sales Order joining these presents (such Sales Order together with any amendments, supplements and additional agreements related thereto and all annexes and schedules in respect thereof, collectively the “Sales Order”); and
 - (b) any affiliates and any party related, whether directly or indirectly, to such “Customer”.

2. LIMITED WARRANTY AND LIABILITY

- 2.1. All units and equipment sold by us to you (collectively “Units”) pursuant to the Sales Order are warranted to be free from defects in material for a period of 2 years from the date of purchase (the “Warranty Period”).
- 2.2. We expressly exclude all warranties whatsoever, other than those included at Section hereof, express or implied, legal or conventional, including, without limitation, any and all warranties of quality, merchantability and fitness for a particular purpose.
- 2.3. We will repair or replace, at our discretion, any defective parts that fail during the Warranty Period. The client will be responsible to return defective parts to the manufacturer’s plant with freight prepaid. This warranty is limited to replacement parts ONLY, subject to on-site or in- house evaluation of defective materials and does not apply to any personal liability or property loss that occurs due to the use or installation of this equipment.
- 2.4. During the Warranty Period, prior to any warranty work being effected, any such work must be pre-approved by us by sending a request to us at service@diversitech.ca in the prescribed warranty claim form available on our website at •. All such work must be completed by us or a party expressly authorized by us. We may charge you any costs, expenses and disbursements incurred by us to effect such work, the whole in our entire discretion.
- 2.5. In the event that you direct a third-party to complete any service or warranty work during the Warranty Period and:
 - (a) the authorization and approval pursuant to Section 2.4 hereof has been received but such third-party has not been expressly authorized by us to complete such work; or
 - (b) the authorization and approval has not been received pursuant to Section 2.4 hereof, then any costs, expenses and disbursements of such third-party for such work shall be borne entirely by you.
- 2.6. Any repair, rework or modifications of any sort, including, without limitation, modifications to software, hardware and components, not authorized by us or completed by anyone other than us, or a party authorized by us, will void the warranty set forth at Section 2.2 hereof.
- 2.7. To the extent that any Units are integrated with any products, equipment, units, connections and/or systems of a third-party (“Third-Party Products”), we hereby expressly exclude all of the following warranties, express or implied, namely:
 - (a) warranty against defects of any kind (latent or apparent), fitness for purpose, merchantability or functionality to the extent of any such Third-Party Products; and
 - (b) any warranty against any defects or problems of any kind, whether latent or apparent, in respect of Units or a Third-Party Product, caused or arising directly or indirectly as a result of the integration with or use of Units in connection with any Third-Party Product.
- 2.8. You hereby expressly waive and renounce to any and all claims against us relating to loss of profits, loss of business or goodwill, interruption of business and all indirect, special, incidental or consequential damages of any kind whether arising from or in connection with the Sales Order or from the use of Units, however caused, and whether in the nature of breach of obligations, breach of warranty, repudiation of contract, tort, negligence (save in the event of gross negligence or intentional fault) or otherwise. Accordingly, save in the event of gross negligence or intentional fault, we shall have no liability whatsoever towards you under these presents or the Sales Order for any losses or damages, direct or indirect, consequential, exemplary, incidental or otherwise, regardless of whether we received advanced notice or were advised of the possibility of such claim, loss or damage.
- 2.9. You are solely responsible for:
 - (a) determining if Units fit your particular purpose and are suitable for your designated process, application, fitment, tooling, set-up and uses(s); and
 - (b) all hazards associated with your processes, products and ingredients, regardless of whether the hazards relate to fire, explosion, material handling, exposure to harmful dusts, fumes or other contaminants, or any other hazard that poses a risk to persons or property.
- 2.10. Unless otherwise expressly agreed and indicated and without limiting any of the foregoing, we do not provide any guarantee or warranty with respect to compliance with process safety, environmental health and safety or codes and standards.
- 2.11. Without limiting any of the foregoing, you hereby undertake to indemnify and hold us harmless and you agree to fully indemnify and defend us, at your sole cost and expense, against any and all present and future, actual, potential, contingent or threatened suits, actions or claims, of any nature or source whatsoever, which may, at any time, be made or asserted against us by any person, including, without limitation, your employees (current or former), contractors, representatives or any third-party, directly or indirectly, for any reason whatsoever, related to and/or arising from exposure to emissions, dust, fumes, pollutants or noxious substances from your processes, materials, ingredients, systems or improper use of Units.

3. FREIGHT CLAIMS

3.1 Shipments must be inspected by you upon arrival. All Units are sold ex-plant. Therefore, it is the receiver's responsibility to file any freight claims with the carrier for obvious or concealed damages. Damaged shipments must be refused at the time of receipt.

4. RETURN MATERIAL POLICY

4.1 Prior to the return of material, for whatever reason, a return merchandise authorization number ("RMA#") is required from our customer service department. This procedure is necessary for proper control and handling of returned materials. Call **1-800-361-3733** or email **support@diversitech.ca** to obtain a RMA #. Credit will be given for returns for warranty repair or replacement. It is the shipper's responsibility to ensure that material being returned to us is adequately packaged for shipment in order to prevent damages.

5. FEES AND CANCELLATION CHARGES

5.1 You will be responsible for any additional charges and fees not expressly included in the Sales Order, including, without limitation, any fees or charges relating to installation, service calls, consulting, installation, customization, "right-sizing", engineering, maintenance and/or repair. For greater certainty, unless expressly provided in the Sales Order, we do not provide you with any form of service with respect to Units, including, without limitation, installation, repair and maintenance services

5.2 In the event that you:

- (a) cancel the Sales Order at any time whatsoever, including, without limitation, prior to shipment;
- (b) refuse to honour the Sales Order; or
- (c) fail to take possession of any Units for any reason whatsoever,

you will be responsible for reimbursement to us of any and all costs, expenses and charges we have incurred to date.

5.3 In the event that:

- (a) the Sales Order is for a customized product, including, without limitation, any custom engineered product; and
- (b) an event set forth at Section **5.2** hereof occurs,

you will be responsible for payment of the entire amount of the Sales Order in addition to the reimbursement set forth at Section **5.2** hereof.

6. JURISDICTION AND ATTORNMENT

6.1 The interpretation, validity and enforcement of these presents and the Sales Order shall be subject to and governed by the laws of the Province of Quebec and the laws of Canada applicable therein.

6.2 The parties hereto expressly submit, attorn and consent to the exclusive jurisdiction of the appropriate Court for the District of Montreal, Province of Quebec, with respect to any controversy arising out of or relating to these presents and the Sales Order, or any supplement hereto or to any transactions in connection therewith. To the extent permitted by applicable law, you irrevocably waive any objection (including any claim of inconvenient forum) that you may now or here after have to the venue of any legal proceeding arising out of or relating to these presents and the Sales Order in such courts.

7. GENERAL

7.1 If any provision of these presents or the Sales Order shall be held to be invalid, illegal or unenforceable, the validity, legality and enforceability of the remaining provisions shall in no way be affected or impaired thereby.

7.2 These presents and the Sales Order shall be binding upon and inure to the benefit of the parties' respective successors and assigns.

7.3 The parties hereto acknowledge that they have requested and are satisfied that the foregoing as well as the Sales Order and all notices, actions and legal proceedings be drawn up in the English language. / Les parties à cette convention reconnaissent qu'elles ont exigé que ce qui précède ainsi que le « Sales Order » et tous avis, actions ou procédures légales soient rédigés et exécutés en anglais et s'en déclarent satisfaites.

For full product support, visit our website;



Part of Absolent Air Care Group

3200 Guenette St
Saint-Laurent, QC H4S 2G5
Email: info@diversitech.ca