



DIVERSITECH
Air Pollution Solutions

Operation & Maintenance Manual

GREEN FILTER CLEANING MACHINE



READ AND SAVE THESE INSTRUCTIONS

Visit our Website for more information on this product



www.diversitech-air.com



www.diversitech.ca

1200 55th Avenue, Montreal, Quebec H8T 3J8

Tel: 1-800-361-3733 | Fax: 1-514-631-9480 | info@Diversitech.ca

TABLE OF CONTENTS

SECTION 1 – SAFETY PRECAUTIONS.....	3
SECTION 2 – PRINCIPLES OF OPERATION.....	3
SECTION 3 – INSTALLATION.....	4
3.1 Upon Arrival.....	4
3.2 Compressed Air Installation.....	4
3.3 Installation of the Barrel.....	5
3.4 Operation.....	5
3.4.1 - Start Up.....	5
3.4.2 - Loading the Filter.....	5
3.4.3 - Open Both End Filters.....	6
3.4.4 - Closed One End Filters.....	6
3.5 Engaging the System.....	7
3.5.1 - LCD Readout.....	7
3.5.2 - Menu.....	8
3.5.3 - Errors.....	9
3.5.4 - Reduce Time of Operation.....	9
3.5.5 - Dry Run.....	9
SECTION 4 – PREVENTIVE MAINTENANCE.....	9
SECTION 5 – TROUBLESHOOTING LIST FOR INJECTION CLEANING SYSTEM.....	10
5.1 Debugging.....	11
SECTION 6 – REPLACEMENT PARTS.....	12
APPENDIX 1 – MAINTENANCE RECORD.....	13
APPENDIX 2 – WIRING SCHEMATIC.....	14
APPENDIX 3 – SPECIFICATIONS.....	14
NOTES.....	15
TERMS AND CONDITIONS TO SALES ORDERS.....	18,19
Back Cover.....	20

SECTION 1 - SAFETY PRECAUTIONS



CAUTION!

This indication refers to matters that have high risk of serious injuries if the system is installed or operated incorrectly.

All users of Diversitech Equipment should comply with all National and Local Fire Codes and/or other appropriate codes when determining the location and operation of dust control equipment.

- Do not use any voltages other than the ones indicated
- Do not cut or damage power cord. Damage to power cord may cause fire or electrical shock
- Flammable Objects-in the event a foreign object should happen to get inside the cabinet, please take the following actions:
 - a. Turn Power Off
 - b. Unplug AC cords
 - c. Remove object
 - d. Resume Operation
- Do not disassemble or modify the system – this may impact the warranty clauses

SECTION 2 - PRINCIPLES OF OPERATION

The Injection Cleaning System (ICS) operates an air nozzle that cleans air filter cartridges. This is accomplished by extreme compressed air originating from the inside-out through the filter. The nozzle rotates 360° while moving up and down to insure cleaning of all the surface area of the air filter.

The cleaning cycle is controlled by a microprocessor based Printed Circuit Board located in the control box. The microprocessor has been programmed to turn on the cleaning system once the filter is sealed ("**Ready to Clean**" appears on the LCD), the start button is pressed and released. The nozzle will travel from its home position (located at the bottom) through the top and then back down to home. The home and top positions are sensed by a limit switch and proximity sensors. Simultaneously, when the gear motor is engaged, an in-line solenoid opens and allows compressed air to reach the nozzle and the air pulse system. If for some reason the Cabinet lid is open before the cleaning system has had a chance to terminate the cycle, the system will shut itself down and resumes from where it left off once the lid is closed and the filter is sealed.

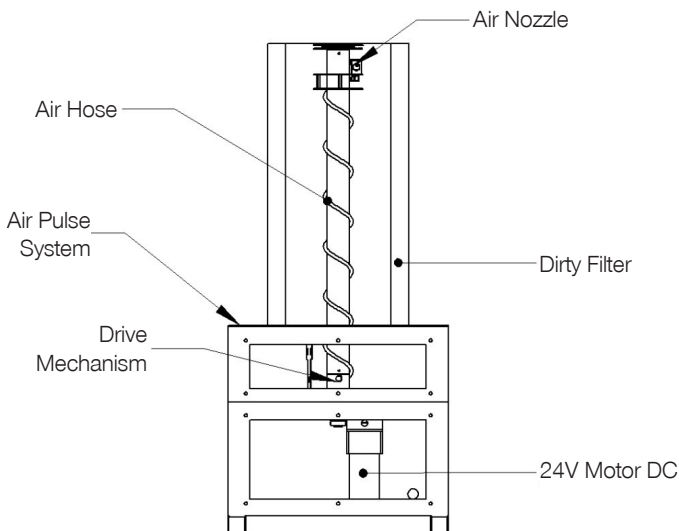

Figure 1: Principle of Operation

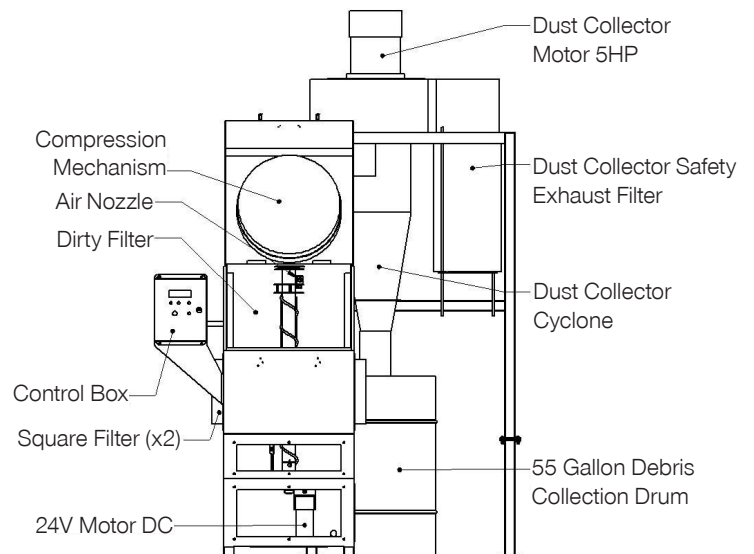

Figure 2: GFCM Major Components

SECTION 3 - INSTALLATION

3.1 Upon Arrival

The Green Filter Cleaning Machine is shipped on a crated skid. The skid should be inspected for any visible damage that may have occurred during shipment. Please advise the Transport Company as soon as possible if the unit appears to have been damaged during shipping.

NOTE: Dust or debris in the machine or cyclone is due to factory testing. Each unit is tested prior to shipping.



WARNING!

Always disconnect power supply before servicing the motor or working with the unit for any reason. All electrical connections must be made by a qualified electrician.

Use suitable floor anchors to securely bolt the machine to the floor. Failure to anchor the machine may result in the machine tipping due to the high center of gravity.

1. Bolt the four legs on the cyclone assembly.
2. Install the Cabinet Assembly and the Cyclone Assembly 12" apart. Using the supplied flex hose, join the Cabinet to the Cyclone. Using hose clamps and silicone to seal the interface between the flexible hose and the metal conduit.

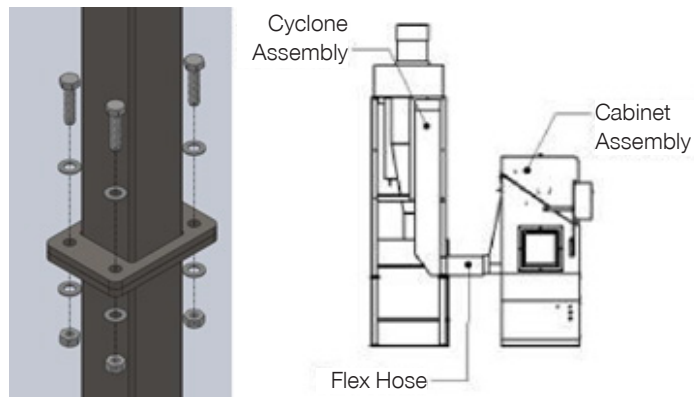

Figure 3: Installation of GFCM

3. Connect the Dust Collector Cyclone Motor to the Control Panel using the Female connector and the Male Plug.



Figure 4: Female Connector & Male Plug

3.2 Compressed Air Installation

NOTE: Only dry compressed air is to be used with the machine. The unit requires a minimum of 80 CFM at 90 PSI to operate properly.

Connect compressed air (90 PSI) to the 1/2" inlet fitting located on the back of the unit. It is recommended to install a cut-off valve on the line for safety purposes. A regulator will be necessary to step down the supply air if the shop pressure is above 100 PSI. NOT complying may result in damage to the unit's components and reduce performance. **A 1/2" NPT supply line is required.**

3.3 Installation of the Barrel

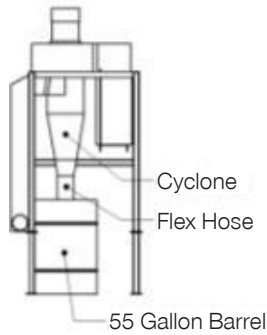

- Step 1: Slide barrel under cyclone cone.
- Step 2: Apply liberal amounts of silicone sealant to the barrel inlet collar.
- Step 3: Slide the flexible hose over the collar.
- Step 4: Fasten the flexible hose to the collar using the provided hose clamp.



Caution!

If Cyclone to Barrel connection is not fully sealed, the cyclone will not operate properly.

3.4 Operation

3.4.1 - Start Up

Before proceeding, one should note that all units have been tested at the factory before shipping. The following steps are to insure proper functioning of the unit and nothing has been damaged during transportation:

1. Check the pneumatic connections on the back of the unit.
2. Connect the air hose and make sure that the air fittings don't leak air.
3. Check that nothing is jammed up against the mechanism.

PLEASE ENSURE THAT CYCLONE MOTOR IS PLUGGED INTO THE CONTROL BOX.

3.4.2 - Loading the Filter

1. Measure the height of filter in inches. (Measuring tape on the side)
2. Refer to Filter Spacer Chart to select spacers required.
 - Step 1: Open the top of the Cabinet by releasing both latches.
 - Step 2: Install required spacers (refer to Filter Spacer Chart)
 - Step 3: Load the filter, then close and secure the latches



IMPORTANT

- DO NOT OPEN LID DURING OPERATION. The cabinet is fitted with a compression mechanism that seals the top of the filter. If the filter is not sealed properly the machine will not operate. Opening the cabinet should only be done after cycle is completed.
- The unit is equipped with a high efficiency cyclone. Any air leaks in the suction or exhaust line (connection to the barrel) may result in some debris accumulating in the exhaust filter. Periodically check the exhaust filter for debris, replace if necessary.
DO NOT PLACE THE EXHAUST FILTER IN THE MACHINE.

3.4.3 - Open Both End Filters

CAUTION: Add Spacers – as required

Please note that the machine only accepts filters within the following size range:

- 10"-to-32"of height
- A minimum of 6.5" of inner diameter
- A maximum of 20" of outer diameter

FILTER SPACER CHART							
Height of Filter to be Cleaned (in.)	# of Spacers Required	1" Spacer	2" Spacer	3" Spacer	4" Spacer	5" Spacer	6" Spacer
32	0						
31	1	1					
30	1		1				
29	1			1			
28	1				1		
27	1					1	
26	1						1
25	2	1					1
24	2		1				1
23	2			1			1
22	2				1		1
21	2					1	1
20	2						2
19	3	1					2
18	3		1				2
17	3			1			2
16	3				1		2
15	3					1	2
14	4	1				1	2
13	4		1			1	2
12	4			1		1	2
11	4				1	1	2
10	5	1			1	1	2

3.4.4 - Closed One End Filters

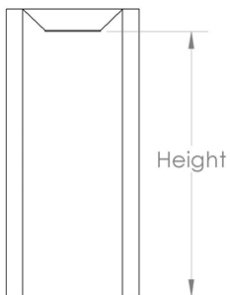

CAUTION: Add Spacers – as required

Please note that the machine only accepts filters within the following size range:

- 10"-to-32"of height
- A minimum of 6.5" of inner diameter
- A maximum of 20" of outer diameter

- Step 1: Measure the height of filter in inches. (See left figure)
- Step 2: Refer to Filter Spacer Chart. (Previous page)
- Step 3: Install required spacers + 1" Spacer

3.5 Engaging the System

The control box includes an LCD screen with a Power rotary switch and a Start, Abort Cycle, Menu/Select & Scroll buttons. A single cleaning cycle is defined as the traveling of the nozzle up and down the filter.

Rotary Switch	Functionality
Power	Turn rotary switch ON to power the controller
Buttons	Functionality
Start	Push Start to begin cleaning cycle
Menu/Select	Push and Hold Menu/Select for one second to enter the Menu
< > (Scroll)	Push < > to scroll over the choices
Abort Cycle	Push Abort Cycle to skip pre-set number of cycles and complete current cycle.

3.5.1 - LCD Readout

LCD Reading	Description
Diversitech GFCM REV 3.0	You are operating Version 3
Going Home 2.5A	The GFCM is resetting itself <ul style="list-style-type: none"> “Going Home”: Machine is resetting itself by returning to home position located at the bottom of the mechanism “2.5A”: Amperage reading of the 24V DC Motor operating the mechanism
Ready to Clean 8 Cycle 23-32"	This is the Home Reading <ul style="list-style-type: none"> “Ready to Clean”: GFCM is ready to clean a dirty filter “8 Cycle”: GFCM will run for 8 cycles “23-32””: The height range of the dirty filter
Clean UP 2.5A 288 Sec CYC 6/8	The GFCM is in operation <ul style="list-style-type: none"> “Clean UP”: The nozzle is rotating while moving upwards “2.5A”: Amperage reading of the 24V DC Motor operating the mechanism “288 Sec”: Indicates the remaining time of the cleaning cycle in seconds “CYC 6/8”: GFCM is at its 6th cycle out of 8th
Clean DOWN 2.5A 288 Sec CYC 6/8	The GFCM is in operation <ul style="list-style-type: none"> “Clean DOWN”: The nozzle is rotating while moving downwards “2.5A”: Amperage reading of the 24V DC Motor operating the mechanism “288 Sec”: Indicates the remaining time of the cleaning cycle in seconds “CYC 6/8”: GFCM is at its 6th cycle out of 8th
Air Jet ON 045 Sec	Air Pulse system is activated <ul style="list-style-type: none"> “Air Jet ON”: Air pulse system to clean the cabinet “045 Sec”: Time left to terminate the Air pulse system
Clean Finished 8 Cycle 23-32"	Cycle has ended <ul style="list-style-type: none"> “Clean Finished”: Cleaning cycles has ended “8 Cycle”: GFCM has cleaned the filter for 8 consecutive cycles “23-32””: The height range of the dirty filter.

3.5.2 - Menu

To enter the Menu: Press and hold Menu/Select Button for 1 second

LCD Reading	Description
Change # Cycles? Y N	<ul style="list-style-type: none"> Press the Scroll Button to the desired selection Press Menu/Select Button to select Yes or No
Select # Cycles 1 2 4 8	Number of Cycles <ul style="list-style-type: none"> Press the Scroll Button to the desired selection Press Menu/Select Button to select 1,2,4 or 8 cycles
Change Filter Height? Y N	<ul style="list-style-type: none"> Press the Scroll Button to the desired selection Press Menu/Select Button to select Yes or No
Filter Height (") 0-16 17-22 23-32	Filter Height Range <ul style="list-style-type: none"> Press the Scroll Button to the desired selection Press Menu/Select Button to select the range of filter that needs to be cleaned 0-16", 17"-22" or 23"-32"
Cycles to Date 65535	The number of cycles the machine has performed up to date. <ul style="list-style-type: none"> Press Menu/Select to return to Home Reading or wait 3 seconds

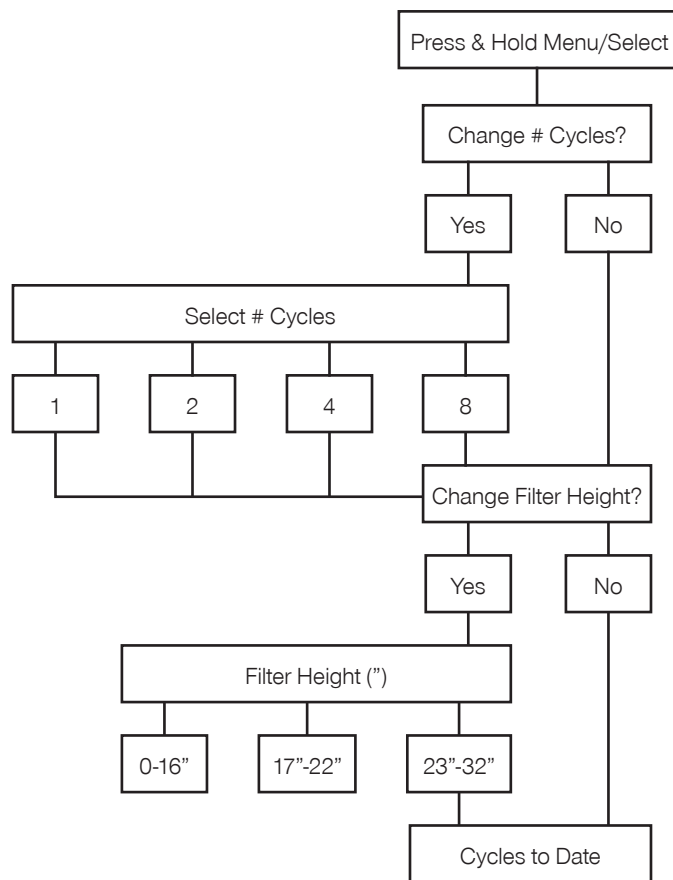

Figure 5: Menu

3.5.3 - Errors

LCD Reading	Description
Filter is not sealed properly	<ul style="list-style-type: none"> • Spacers not installed / Incorrect Spacer Height • Cabinet Lid not secured properly
Clean UP 2.5A Counter Error	<ul style="list-style-type: none"> • Proximity Sensor Failure while cleaning upwards – Replace it with the one provided in the bottom of the Cabinet
Clean DOWN 2.5A Counter Error	<ul style="list-style-type: none"> • Proximity Sensor Failure while cleaning downwards - Replace it with the one provided in the bottom of the Cabinet
Clean UP 8.5A Overcurrent STOP	<ul style="list-style-type: none"> • Nozzle is jammed while cleaning upwards - Verify that the nozzle is not jammed up against an obstruction
Clean DOWN 8.5A Overcurrent STOP	<ul style="list-style-type: none"> • Nozzle is jammed while cleaning downwards - Verify that the nozzle is not jammed up against an obstruction
Clean DOWN 0.0A Home SW ERROR	<ul style="list-style-type: none"> • Home position is misplaced. Manually turn tube CCW for the nozzle to move upwards. Remove Maintenance panel and adjust Limit Switch to the correct position.

Contact Diversitech support at 1-800-361-3733

3.5.4 - Reduce Time of Operation

A full 23"-32" cycle takes approximately 5 minutes to end. The cycle time could be reduced by 25-to-50% **if and only if the filter is open on both ends and the height of filter is equal or less than 22"**. This could be accomplished by setting the filter height (Figure 5) to 0-16" or 17"-22". One should note that loading the filter defers from the usual procedure. (Read procedure below)

Step 1: Install the filter

Step 2: Add the required spacers on top of the filter (Rather than adding them at the bottom)

3.5.5 - Dry Run

Dry Run is to operate the GFCM without any air supply. This is only to observe any malfunctioning components or to trouble shoot issues that the GFCM may encounter.

SECTION 4 - PREVENTIVE MAINTENANCE

1. Injection Cleaning System

Regular checklist:

- Inspect the Limit switch at the bottom of the assembly for any debris
- Ensure that the Nozzle Assembly disc properly aligns with the Limit switch to ensure that contact occurs.

This can be achieved doing a "Dry Run".

Step 1: Open the top by releasing both latches.

Step 2: Remove filters/spacers inside the Cabinet.

Step 3: Cut air supply to the unit.

Step 4: There is a Maintenance switch on the side of the Cabinet below the Control Box, turn this switch on.

Step 5: Once the LCD reads "Ready to Clean"

Step 6: Press the start button

Step 7: Let the unit run up & down.

Once this checklist is verified, please turn OFF the switch on the side of the Cabinet below the Control Box. This switch is for maintenance only.

2. Hardware

Bolts and nuts should be checked periodically and tightened.

3. Dust Barrel

Empty out the contents of the dust barrel periodically. Please ensure that the materials are disposed of properly in accordance with local disposal laws.

Important Note: Barrel should not be more than ¾ full.

4. Exhaust Filter

After cleaning filters visually inspect the exhaust filter located behind the cyclone. Replace the filter when necessary.

Important Note: Do not place Exhaust filter into the machine.

5. Cabinet debris

After every 24 filters cleaned remove panel in front of the Cabinet, inspect and vacuum (if necessary) around the cleaning mechanism base.

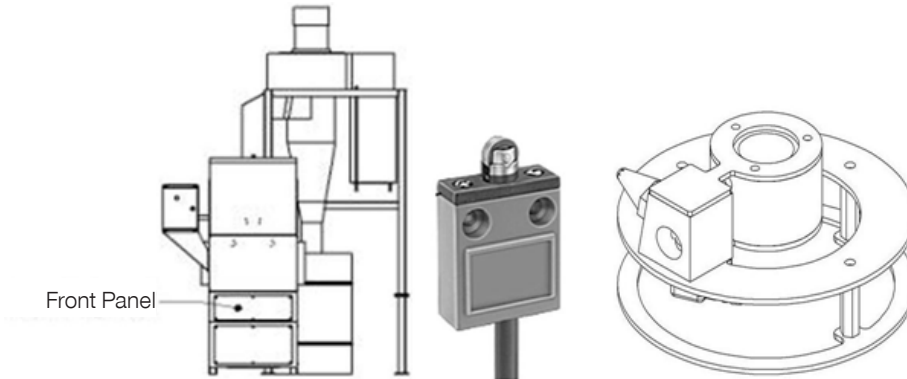

Figure 6: Front Panel, Limit Switch and Nozzle Assembly

SECTION 5 - TROUBLESHOOTING LIST FOR INJECTION CLEANING SYSTEM

PROBLEM	CAUSE	SOLUTION
System is NOT turning	Power is not supplied to PC board.	Ensure the unit is plugged in; ensure there is no loose or short wiring between primary & secondary of transformer and the 24VAC power inlets of PC Board.
	Filter is not sealed properly	Check the compression mechanism on top of the inner chamber lid. Insert appropriate Spacer. (Refer to Filter Spacer Chart)
	Loose connection between PC board and motor.	Check motor connection. When the “UP” light is ON, the motor should be rotating the nozzle upwards; and downwards when the “DOWN” light is ON. (Refer to the electrical diagram)
	This could be a result of the nozzle being jammed, or of something restricting free movement of the nozzle.	Locate and repair the cause of the physical restriction before operating the system.
	Limit switch needs alignment	Push limit switch forward or backwards to align with the Nozzle Assembly switch disc
System is NOT turning and no air comes out of the nozzle.	Solenoid is not opening.	Upon a cleaning cycle, the “SOLN1” light turns ON indicating power is being supplied to the solenoid. Check the wiring between the PC board and the solenoid for any possible bad connections. Check if solenoid is operational. This can be done by jumping the solenoid leads to the secondary side of the transformer. (24VAC) If both wiring and solenoid are in order, the PC board might need to be changed.
System turns but no air comes out of the nozzle.	Low air supply pressure.	Ensure that air pressure is 80-100psi and Minimum 80CFM
	The nozzle is blocked by dirt or other contaminant.	Remove blockage from the nozzle. Check if pneumatic filter is filtering air properly. Its filter unit might need to be replaced.
Not enough air coming out of the nozzle.	There is an air leak in the pneumatic system.	Verify pneumatic system for leaks and tighten or change hose clamps or hoses.

Contact Diversitech support at 1-800-361-3733

Things to check

When the machine is first plugged in, the mechanism will move to a "home" position. Once the nozzle is at home position, the system is ready. The cleaning cycle is controlled by a microprocessor based PC board located in the control box. The microprocessor has been programmed to turn on the cleaning system once the start button is pressed and released, and the filter is sealed. The nozzle will travel from its home position (located at the bottom) through the top and back down to home. The home and top positions are sensed by Limit Switch and Proximity Sensor respectively. Simultaneously, when the gear motor is engaged, an in-line solenoid opens and allows compressed air to reach the nozzle or the pneumatic vibrator motor. If for some reason the lid is open before the cleaning system has had a chance to terminate the cycle, the system will shut itself and the unit will resume from where it left off once the Cabinet lid is closed.

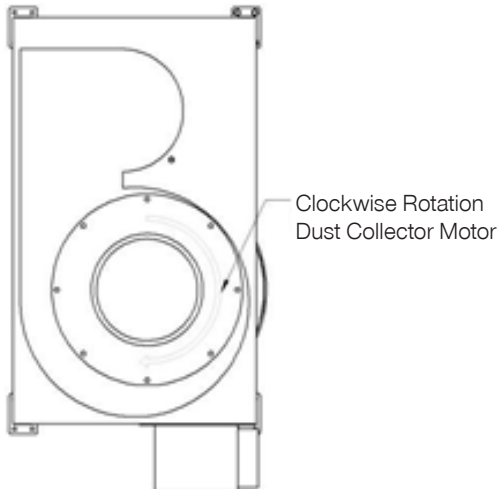

1. Cyclone Assembly

- a. Dust Collector Motor 5HP
 - i. Depending on the voltage used the running amperage differs on every machine.
 - ii. Look for Maximum Amperage (Max. AMP.) on Serial Number Sticker located on left side of the Control box. (e.g. For a 460V/3P/60Hz the maximum amperage is 6.1A)
 - iii. Hook an Amperage meter to the T1 in the control box. The running amperage readout should be below the Maximum Amperage. (e.g. For a 460V/3P/60Hz the running amperage is around 5-to-5.5A). If the amperage is higher, shut down the power and invert the L1 with L2.
 - iv. Rotation of Motor is Clockwise from the top view.
- b. Dust Collector Motor 5HP is not starting
 - i. Verify the Male and Female connector plug. Insure they are well connected.

2. Mechanism check

- a. During operation verify that the Amperage readout on the LCD is not higher than 5Amps. The machine must be shut down and maintenance clean up should be performed on cleaning mechanism of the GFCM.
- b. Maintenance Switch located under the Control Box. Cut air supply to the GFCM and turn on the maintenance switch. Observe the cleaning mechanism while it goes up and down. If an error appears see **section 3.5.3 Errors**

SECTION 6 - REPLACEMENT PARTS

PART NUMBERS	REPLACEMENT PARTS
GFCM-001	PAPER CARTRIDGE FILTER EXHAUST
GFCM-001P	POLYESTER CARTRIDGE FILTER EXHAUST-STANDARD
GFCM-001NF	NANOFIBER CARTRIDGE FILTER EXHAUST
GFCM-002	SPUNBOND INTAKE PANEL FILTER 12X12X2
GFCM-004	24 VDC GEARMOTOR
GFCM-005	GEARMOTOR CABLE
GFCM-006	SENSOR CABLE
GFCM-008	5 HP/230-380-460-600V/3/50-60Hz MOTOR
GFCM-009	5 BI CCW BLOWER WHEEL
GFCM-010	5 BLOWER CONE
GFCM-011	BARREL PLUGS
GFCM-012	BARREL KNOBS
GFCM-013	CYCLONE
GFCM-014	LIMIT SWITCH
GFCM-015	PROXIMITY SENSOR
GFCM-016	RECOIL HOSE
GFCM-017	AIR NOZZLE
GFCM-018	RARE EARTH MAGNETS
GFCM-019	MOTOR STARTER
GFCM-020	230/380/460/600 - 24 VAC TRANSFORMER
GFCM-021	PC-BOARD
GFCM-022	FUSE
GFCM-024	24VAC SOLENOID VALVE
GFCM-026	6"dia FLEXHOSE (SPECIFY LENGTH WHEN ORDERING)
GFCM-027	CYCLONE EXHAUST BARREL

APPENDIX 2 - WIRING SCHEMATIC

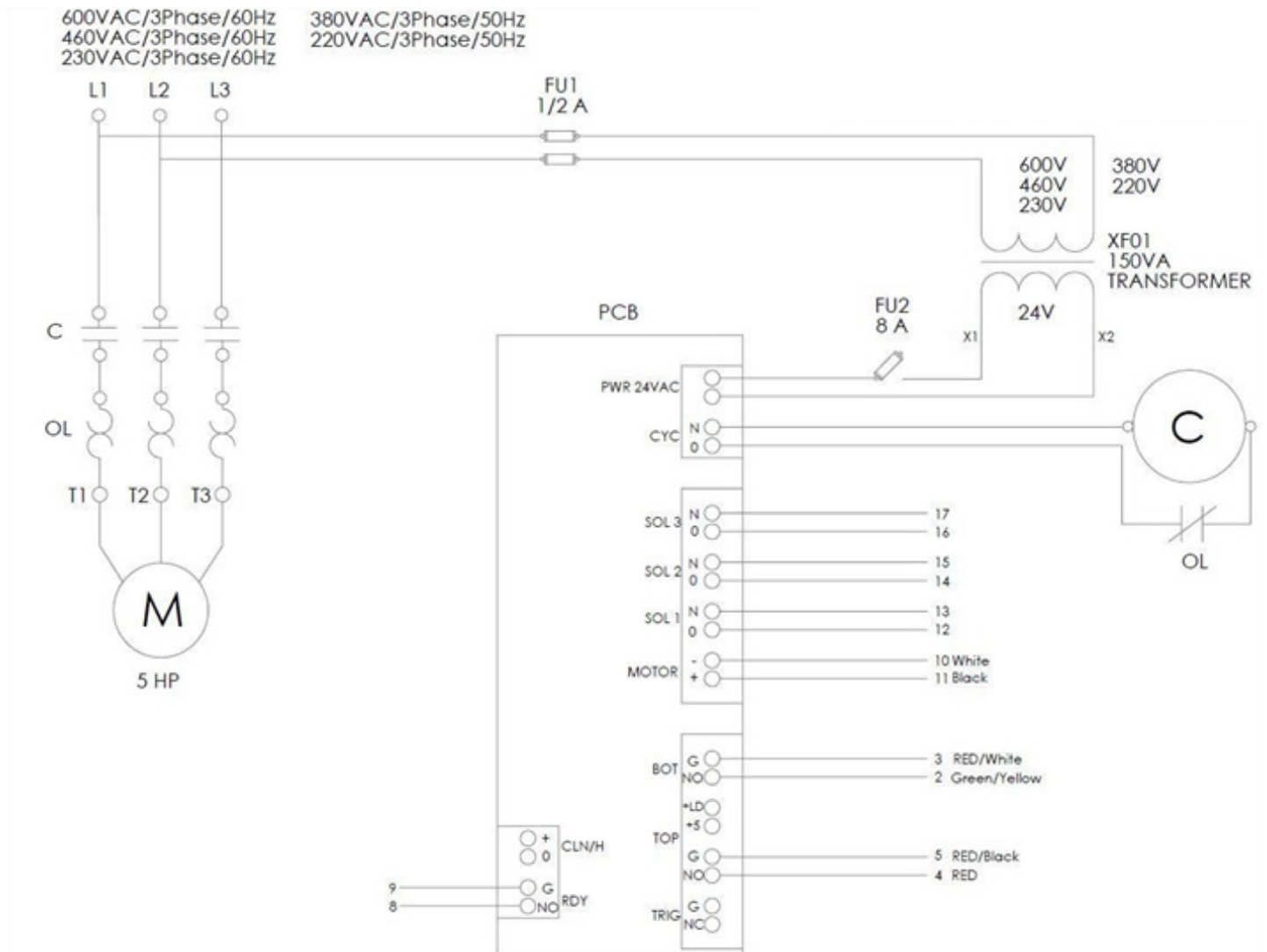

APPENDIX 3 - SPECIFICATIONS

Specifications	
Overall Dimensions	6' Wide x 6' Deep x 8'8" High
Compressed Air Requirements	90 PSI, 1/2" air line, 80 CFM
Electrical Requirements	208-230V/380V/460V/600V/3P/60Hz
Cyclone Motor	5HP 208-230V/380V/460V/600V, 3-phase, 2800 RPM or 3400 RPM, 50hz or 60Hz
Cyclone	1400 CFM at 4" static pressure
Electrical	Enclosure combines motor starter for 5HP motor and I.C.S. Motor
Filter Height Range	Up to 32" high
Filter Diameter Range	6.5" Inner diameter, 20" maximum outer diameter
Cycle Time	Approx. 4-5 Minutes

TERMS AND CONDITIONS TO SALES ORDERS

1. INTERPRETATION

- 1.1. All references to "we", "us" or "our" herein mean Diversitech Equipment and Sales (1984) Ltd.
- 1.2. All references to "you" or "your" herein mean:
 - (a) the "Customer" referred to herein and in the Sales Order joining these presents (such Sales Order together with any amendments, supplements and additional agreements related thereto and all annexes and schedules in respect thereof, collectively the "Sales Order"); and
 - (b) any affiliates and any party related, whether directly or indirectly, to such "Customer".

2. LIMITED WARRANTY AND LIABILITY

- 2.1. All units and equipment sold by us to you (collectively "Units") pursuant to the Sales Order are warranted to be free from defects in material for a period of 2 years from the date of purchase (the "Warranty Period").
- 2.2. We expressly exclude all warranties whatsoever, other than those included at Section hereof, express or implied, legal or conventional, including, without limitation, any and all warranties of quality, merchantability and fitness for a particular purpose.
- 2.3. We will repair or replace, at our discretion, any defective parts that fail during the Warranty Period. The client will be responsible to return defective parts to the manufacturer's plant with freight prepaid. This warranty is limited to replacement parts ONLY, subject to on-site or in-house evaluation of defective materials and does not apply to any personal liability or property loss that occurs due to the use or installation of this equipment.
- 2.4. During the Warranty Period, prior to any warranty work being effected, any such work must be pre-approved by us by sending a request to us at service@diversitech.ca in the prescribed warranty claim form available on our website at •. All such work must be completed by us or a party expressly authorized by us. We may charge you any costs, expenses and disbursements incurred by us to effect such work, the whole in our entire discretion.
- 2.5. In the event that you direct a third-party to complete any service or warranty work during the Warranty Period and:
 - (a) the authorization and approval pursuant to Section 2.4 hereof has been received but such third-party has not been expressly authorized by us to complete such work; or
 - (b) the authorization and approval has not been received pursuant to Section 2.4 hereof, then any costs, expenses and disbursements of such third-party for such work shall be borne entirely by you.
- 2.6. Any repair, rework or modifications of any sort, including, without limitation, modifications to software, hardware and components, not authorized by us or completed by anyone other than us, or a party authorized by us, will void the warranty set forth at Section 2.2 hereof.
- 2.7. To the extent that any Units are integrated with any products, equipment, units, connections and/or systems of a third-party ("Third-Party Products"), we hereby expressly exclude all of the following warranties, express or implied, namely:
 - (a) warranty against defects of any kind (latent or apparent), fitness for purpose, merchantability or functionality to the extent of any such Third-Party Products; and
 - (b) any warranty against any defects or problems of any kind, whether latent or apparent, in respect of Units or a Third-Party Product, caused or arising directly or indirectly as a result of the integration with or use of Units in connection with any Third-Party Product.
- 2.8. You hereby expressly waive and renounce to any and all claims against us relating to loss of profits, loss of business or goodwill, interruption of business and all indirect, special, incidental or consequential damages of any kind whether arising from or in connection with the Sales Order or from the use of Units, however caused, and whether in the nature of breach of obligations, breach of warranty, repudiation of contract, tort, negligence (save in the event of gross negligence or intentional fault) or otherwise. Accordingly, save in the event of gross negligence or intentional fault, we shall have no liability whatsoever towards you under these presents or the Sales Order for any losses or damages, direct or indirect, consequential, exemplary, incidental or otherwise, regardless of whether we received advanced notice or were advised of the possibility of such claim, loss or damage.
- 2.9. You are solely responsible for:
 - (a) determining if Units fit your particular purpose and are suitable for your designated process, application, fitment, tooling, set-up and uses(s); and
 - (b) all hazards associated with your processes, products and ingredients, regardless of whether the hazards relate to fire, explosion, material handling, exposure to harmful dusts, fumes or other contaminants, or any other hazard that poses a risk to persons or property.
- 2.10. Unless otherwise expressly agreed and indicated and without limiting any of the foregoing, we do not provide any guarantee or warranty with respect to compliance with process safety, environmental health and safety or codes and standards.
- 2.11. Without limiting any of the foregoing, you hereby undertake to indemnify and hold us harmless and you agree to fully indemnify and defend us, at your sole cost and expense, against any and all present and future, actual, potential, contingent or threatened suits, actions or claims, of any nature or source whatsoever, which may, at any time, be made or asserted against us by any person, including, without limitation, your employees (current or former), contractors, representatives or any third-party, directly or indirectly, for any reason whatsoever, related to and/or arising from exposure to emissions, dust, fumes, pollutants or noxious substances from your processes, materials, ingredients, systems or improper use of Units.

3. FREIGHT CLAIMS

3.1 Shipments must be inspected by you upon arrival. All Units are sold ex-plant. Therefore, it is the receiver's responsibility to file any freight claims with the carrier for obvious or concealed damages. Damaged shipments must be refused at the time of receipt.

4. RETURN MATERIAL POLICY

4.1 Prior to the return of material, for whatever reason, a return merchandise authorization number ("RMA#") is required from our customer service department. This procedure is necessary for proper control and handling of returned materials. Call **1-800-361-3733** or email **support@diversitech.ca** to obtain a RMA #. Credit will be given for returns for warranty repair or replacement. It is the shipper's responsibility to ensure that material being returned to us is adequately packaged for shipment in order to prevent damages.

5. FEES AND CANCELLATION CHARGES

5.1 You will be responsible for any additional charges and fees not expressly included in the Sales Order, including, without limitation, any fees or charges relating to installation, service calls, consulting, installation, customization, "right-sizing", engineering, maintenance and/or repair. For greater certainty, unless expressly provided in the Sales Order, we do not provide you with any form of service with respect to Units, including, without limitation, installation, repair and maintenance services

5.2 In the event that you:

- (a) cancel the Sales Order at any time whatsoever, including, without limitation, prior to shipment;
- (b) refuse to honour the Sales Order; or
- (c) fail to take possession of any Units for any reason whatsoever,

you will be responsible for reimbursement to us of any and all costs, expenses and charges we have incurred to date.

5.3 In the event that:

- (a) the Sales Order is for a customized product, including, without limitation, any custom engineered product; and
- (b) an event set forth at Section **5.2** hereof occurs,

you will be responsible for payment of the entire amount of the Sales Order in addition to the reimbursement set forth at Section **5.2** hereof.

6. JURISDICTION AND ATTORNMENT

6.1 The interpretation, validity and enforcement of these presents and the Sales Order shall be subject to and governed by the laws of the Province of Quebec and the laws of Canada applicable therein.

6.2 The parties hereto expressly submit, attorn and consent to the exclusive jurisdiction of the appropriate Court for the District of Montreal, Province of Quebec, with respect to any controversy arising out of or relating to these presents and the Sales Order, or any supplement hereto or to any transactions in connection therewith. To the extent permitted by applicable law, you irrevocably waive any objection (including any claim of inconvenient forum) that you may now or here after have to the venue of any legal proceeding arising out of or relating to these presents and the Sales Order in such courts.

7. GENERAL

7.1 If any provision of these presents or the Sales Order shall be held to be invalid, illegal or unenforceable, the validity, legality and enforceability of the remaining provisions shall in no way be affected or impaired thereby.

7.2 These presents and the Sales Order shall be binding upon and inure to the benefit of the parties' respective successors and assigns.

7.3 The parties hereto acknowledge that they have requested and are satisfied that the foregoing as well as the Sales Order and all notices, actions and legal proceedings be drawn up in the English language. / Les parties à cette convention reconnaissent qu'elles ont exigé que ce qui précède ainsi que le « Sales Order » et tous avis, actions ou procédures légales soient rédigés et exécutés en anglais et s'en déclarent satisfaites.

For full product support, visit our website;
<https://bit.ly/2oc1bTg>



Scan above on mobile



An Absolent Group
Company



1200 55th Avenue
Montreal, Quebec H8T 3J8
Email: info@diversitech.ca