



DIVERSITECH
Air Pollution Solutions

Operation & Maintenance Manual

FILTERHAWK AMBIENT AIR CLEANER AM SERIES



READ AND SAVE THESE INSTRUCTIONS

Visit our Website for more information on this product



www.diversitech-air.com



www.diversitech.ca

1200 55th Avenue, Montreal, Quebec H8T 3J8
Tel: 1-800-361-3733 | Fax: 1-514-631-9480 | info@diversitech.ca

TABLE OF CONTENTS

- SECTION 1 – SAFETY & INSPECTION3
 - 1.1 Safety3
 - 1.2 Inspection3
- SECTION 2 – SPECIFICATIONS4
 - 2.1 Product Specifications.....4
 - 2.2 Dimensions4
- SECTION 3 – INSTALLATION5
- SECTION 4 – REPLACEMENT PARTS6
- SECTION 5 – ELECTRICAL7
- SECTION 6 – TROUBLESHOOTING7
 - 6.1 Troubleshooting Chart7
 - 6.2 Blower Operation8
 - 6.3 Blower Maintenance8
 - 6.4 Blower Troubleshooting Chart9
- APPENDIX 1 - MAINTENANCE RECORD10
- NOTES11,12,13
- TERMS AND CONDITIONS TO SALES ORDERS.....14,15
- Back Cover.....16

SECTION 1 - SAFETY & INSPECTION



READ
BEFORE
USE

This manual contains specific cautionary statements related to worker safety. To protect yourself and others, read this manual thoroughly and follow as directed before use. Not all hazards of fume & dust control are listed in this manual, and no hazards related to welding, cutting, grinding, painting, deburring or other applications are listed. Consult a qualified safety professional.

1.1 Safety

- Follow all building and safety codes when installing this equipment. Pertaining but not limited to, the Occupational Safety and Health Act (OSHA), National Electric Code (NEC), Uniform Building Code (UBC), National Fire Prevention Act (NFPA) & all state and local codes.
- All electrical connections should be performed by a qualified electrician.
- Keep Flammable Objects away from the air cleaner and under no condition should a burning object be allowed into the air cleaning system.
- Take proper caution in placing units in buildings with radiant heaters installed. Follow the radiant heater manufacturer's guidelines for clearance to combustibles.
- Do not mix materials collected in your Air Cleaner. Materials collected could create a hazardous environment or a condition of operation for which the equipment was not intended. The Manufacturer is relieved of any liability if this unit is not used according to this manual.
- Do not use the Air Cleaner for an application other than for which it was intended. Consult your distributor, Applicable Codes, or call Diversitech for application assistance.
- Fire protection is not included. Please consult your local fire protection specialist for any required extinguishing equipment.
- Diversitech reserves the right to make design changes which may improve the air cleaner.
- This unit is intended for use to collect ambient dust, smoke, fume and other airborne pollutants in industrial and manufacturing Facilities. Do not use for the collection of flammable or explosive metals, dusts, fumes or other potentially hazardous materials.

1.2 Inspection

Upon receiving your Diversitech air cleaner, please inspect for any damage incurred during shipment. Inspect carefully, some damage may not be noticeable until the unit is installed. Notify your shipper of any damage immediately. Claims must be filed with the shipper within 15 days. Freight damage claims are the responsibility of the purchaser.

SECTION 2 - SPECIFICATIONS

2.2 Product Specifications

Model	Airflow (CFM)	Motor (H.P.)	Pre Filter Type	Paper Pleated Filter	Bag Air Filter	Blower	Input Power (v/p/hz)	F.L.A (amps)
AM-3000	3000	1.5	(2) MERV 7	(2) MERV 8	(2) MERV 14	Belt Drive	120v/1/60Hz	15.5
AM-4500	4500	3.0	(2) MERV 7	(2) MERV 8	(2) MERV 14	Belt Drive	230/460/575v/3/60Hz	9.6/4.8/3.9

2.4 Dimensions

Model	Product Dimensions (in.)			Net Weight (lbs.)
	Height (in.)	Length (in.)	Depth (in.)	
AM-3000	25	72	25	390
AM-4500	25	72	25	428

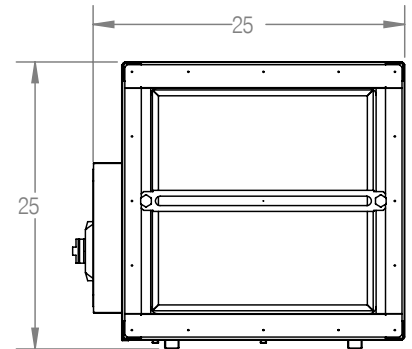
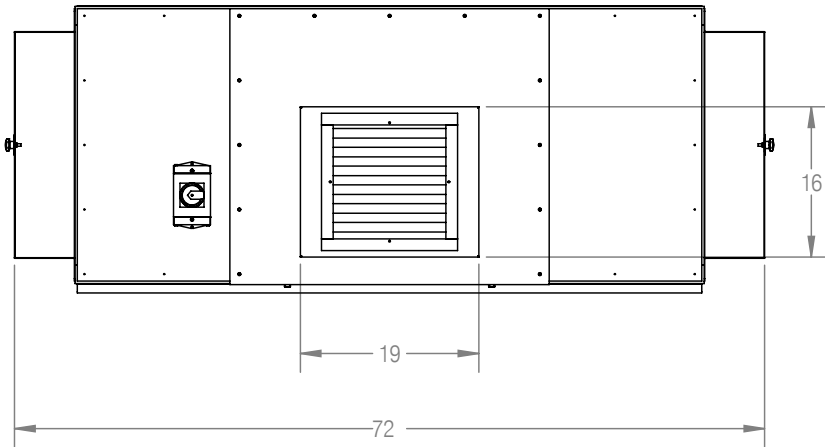

SECTION 3 - INSTALLATION

The system's weight must be taken into account when choosing the proper installation method (see specification). Follow all applicable building and electrical codes.

There are three main ways of installing your air cleaner, Chain Hanging (eye bolts factory installed), rod & cradle , or angle braces. Figure 2 illustrates these methods.

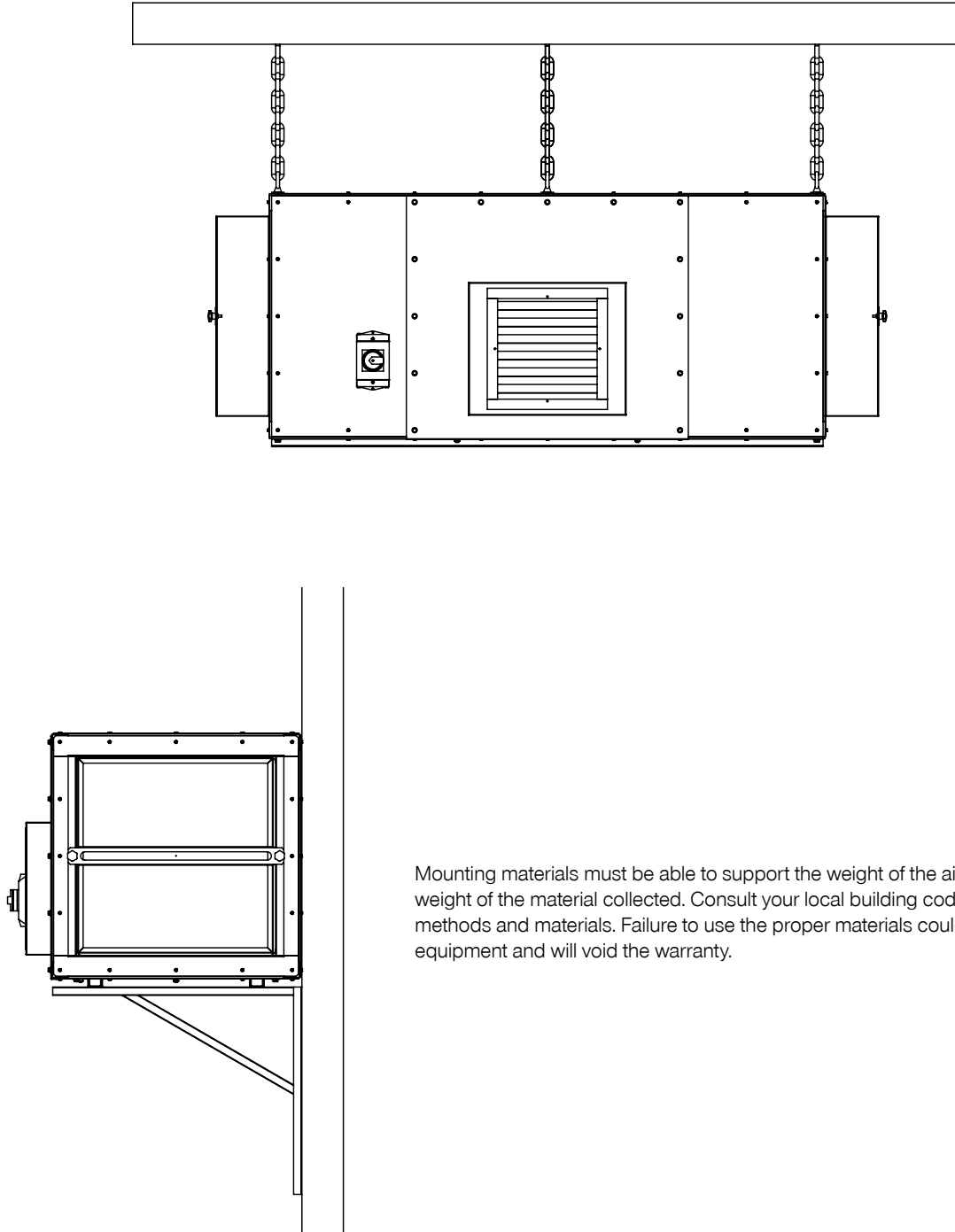

Mounting materials must be able to support the weight of the air cleaner plus the additional weight of the material collected. Consult your local building code for proper installation methods and materials. Failure to use the proper materials could result in injury or damage equipment and will void the warranty.

SECTION 4 - REPLACEMENT PARTS

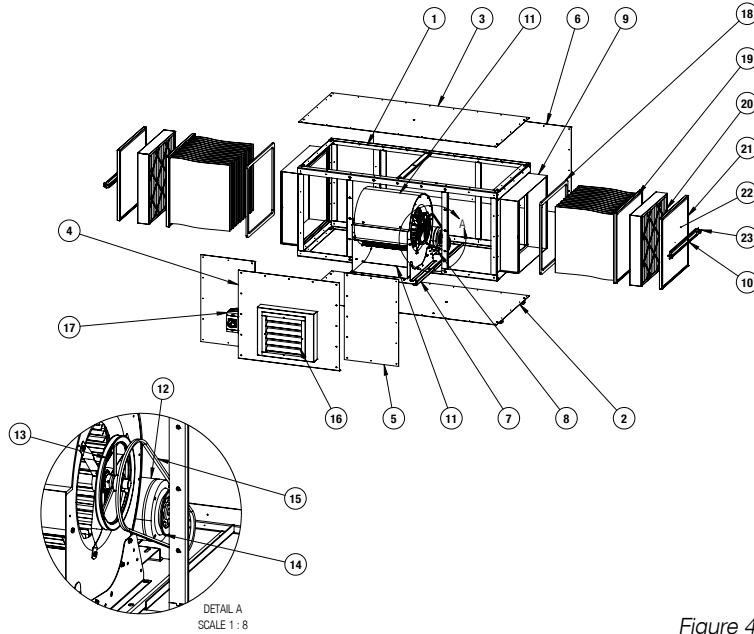
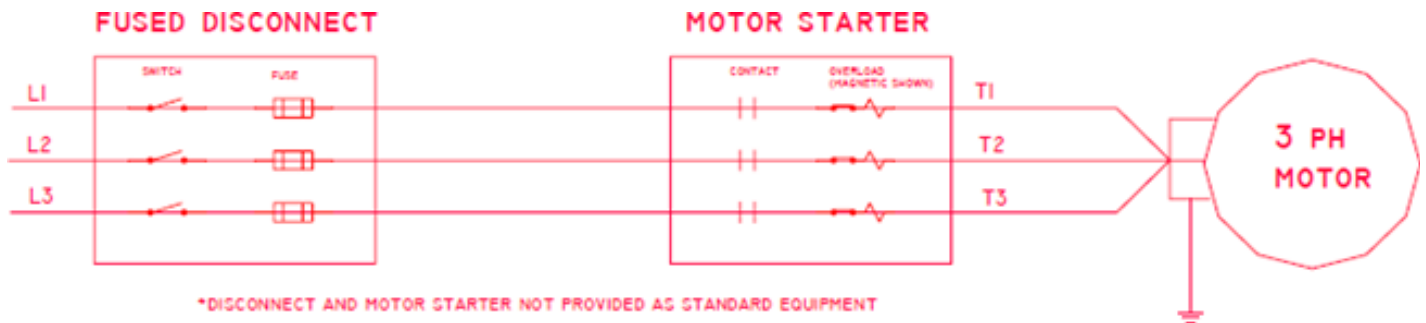

Figure 4

Item #	Part #	Inventory #	Description	Material	
1	AC_FRAME	SUB ASSEMBLY	FRAME	CRS SHEET [12ga]	1
2	AC_BOTTOM	SUB ASSEMBLY	BOTTOM	CRS SHEET [14ga]	1
3	AC_TOP PLATE	INV-AC-TOPPLATE	TOP PLATE, 66.5 X 29.5	CRS SHEET [18ga]	1
4	AC_FRONT	SUB ASSEMBLY	FRONT COVER	CRS SHEET [18ga]	1
5	AC_FRONT PLATE 02	INV-AC-FSPLATE-02	FRONT SIDE PLATE	CRS SHEET [18ga]	2
6	AC_BACK PLATE	INV-AC-BACKPLATE	BACK PLATE, 66.5 X 29	CRS SHEET [18ga]	1
7	AC_BLOWER PLATE 01	INV-AC-BPLATE	BLOWER PLATE	CRS SHEET [12ga]	1
8	AC_MOTOR BRACKET	SUB ASSEMBLY	MOTOR BRACKET	CRS SHEET [12ga]	1
9	AC_FILTER HOUSING	SUB ASSEMBLY	FILTER SIDE	CRS SHEET [16ga]	2
10	AC_FILTER BRACKET	INV-AC-FBRACKET	FILTER BRACKET	CRS SHEET [16ga]	2
11	HARD	INV-MOTR-0731	DELHI G-SERIES DOUBLE INLET BLOWER, MODEL G15	STEEL	1
12	HARD	INV-145T-030-5-ODP-1800	MOTOR, 3HP, 575V, 60HZ, 3PH, 1725 RPM		1
13	HARD	INV-MISC-1389	PULLEY, 4L, A V-BELT, 10"OD FOR 1" SHAFT DIA		1
14	HARD	INV-MISC-1400	V-BELT-PULLY, 4L, A, AX AND 5L, B, BX BELTS, 4.95"PD, FOR 5/8" SHAFT		1
15	HARD	INV-MISC-1393	V-BELT, A56, 58" DOUTER CIRCUMFERENCE		1
16	HARD	INV-DUCT-1733	FIXED-BLADE WALL LOUVER		1
17	HARD	INV-CRTL-0090	ON-OFF SWITCH		1
18	HARD	INV-SEAL-1037	GASKET, CELL NEOPRENE 1/4" THK X 1"W X 8FT		1
19	HARD	INV-FILT-0141	BAG AIR FILTER, MERV 14, 21" X 24" X 24", 10 POCKET		2
20	HARD	INV-FILT-0142	PAPER PLEATED AIR FILTER, 4" X 24" X 24", MERV 8.		2
21	HARD	NV-FILT-8759	PRE-FILTER FRAME, , 1" X 24" X 24"		2
22	HARD	INV-FILT-0751	FILTER SAVER PAD, 27" X 27" X 2", MERV 7		2
23	HARD	INV-HARD-0464	NYLON KNOB - 0.25"-20 X 3/4"		4

SECTION 5 - ELECTRICAL

3 PHASE ELECTRICAL DIAGRAM



Additional wiring will be required to get power to unit, which is not supplied with this product.

Motor Starters, disconnect, wiring, overloads, and thermal protection are NOT provided by the Manufacturer

All Field wiring should be performed by a qualified electrician and must meet all local, NFPA and NEC codes. Failure to install the proper electrical wiring, thermal protection, and controls will void the warranty.

After completion of the field wiring, turn the unit on to check for proper rotation. Rotation is marked on the side of the blower housing. Backward rotation will result in a much lower air flow, louder noise, and will over amp the motor. Check the motor nameplate before switching wires and reversing rotation, to ensure the unit is operating at or below rated amp draw.

SECTION 6 - TROUBLESHOOTING



WARNING!

Recommended Maintenance: Remove dirt accumulations in and around vent openings, by vacuuming. Dirt accumulations can cause motor overheating and a fire hazard. Enclosed motors can be cleaned with an air jet; wear eye protection.

Periodically inspect the installation. Check for dirt accumulations; unusual noises or vibration; overheating; worn or loose couplings, sheaves and belts; high motor current; poor wiring or overheated connections; loose mounting bolts or guards; and worn motor starter contacts.

6.1 Troubleshooting Chart

This chart suggests common answers to electric motor problems. The information is not all-inclusive and does not necessarily apply in all cases. When unusual operating conditions, repetitive failures, or other problems occur, consult an electric motor service firm for assistance.

Symptom	Possible Cause(s)	Corrective Action
Motor fails to start	<ol style="list-style-type: none"> Blown fuses Voltage too low at motor terminals due to line drop Overload in motor starter tripped Overload (internal thermal protector) tripped Improper line connections Motor may be overloaded Defective motor or starter. 	<ol style="list-style-type: none"> Replace with time-delay fuses. Check for grounded winding Consult local power company. Increase wire size (refer to Tables A & B). Check for poor connections Check and reset overload relay in starter. Check heater rating against motor nameplate current rating Check motor load. If motor has an automatic or manual reset thermal protector, check if tripped Check connections against diagram supplied with motor Reduce load or increase motor size Repair or replace
Motor does not come up to speed or takes too long to accelerate	<ol style="list-style-type: none"> Not applied properly. Voltage too low at motor terminals Starting load too high. Excess loading; tight belts Defective motor Inadequate starting torque. High inertia load 	<ol style="list-style-type: none"> Consult motor service firm for proper type. Use larger motor. Increase wire size (refer to Tables A & B). Check for poor connections. Check for voltage unbalance (3-Phase) Check load motor is carrying at start. Reduce load; adjust belts. Increase motor size. Repair or replace Replace with larger motor
Motor stalls during operation	<ol style="list-style-type: none"> Overloaded motor Low motor voltage 	<ol style="list-style-type: none"> Reduce load or increase motor size Verify that nameplate voltage is maintained

Symptom	Possible Cause(s)	Corrective Action
Motor vibrates or is excessively noisy	<ol style="list-style-type: none"> 1. Motor shaft misaligned 2. 3-phase motor running on single phase 3. High or unbalanced voltages 4. Worn, damaged, dirty or overloaded bearings 5. Defective winding. Bent or bowed shaft 6. Loose sheave or misaligned coupling 	<ol style="list-style-type: none"> 1. Realign 2. Check for open circuit, blown fuses or unbalanced voltages 3. Check wiring connections. Consult local power company 4. Replace bearings; check loading and alignment 5. Repair or replace 6. Tighten set screw(s); realign coupling
Motor overheats while running under load	<ol style="list-style-type: none"> 1. Overloaded 2. Dirt blocking 3. If 3-Phase, one phase may be open 4. Unbalanced supply voltage 5. Faulty connection 6. High or low voltage 7. Defective motor 	<ol style="list-style-type: none"> 1. Reduce load; adjust belts. Increase motor size. 2. Clean motor 3. Check lines for open phase. Check voltage with motor disconnected, one fuse may be blown. 4. Check for faulty connections. Voltage on all three lines should be balanced within 1%. Balance single phase loads. 5. Clean, tighten, or replace 6. Check voltage at motor, should not be more than 10% above or below rated 7. Repair or replace

6.2 Blower Operation

After electrical connections are completed, start motor briefly to determine the direction of wheel rotation. If necessary to reverse the rotation, follow instructions given on the motor nameplate or terminal box cover.

With air system in full operation, and with all ducts attached and inspection door(s) closed, measure the current input to the motor and compare with nameplate rating to determine if the motor is operating under safe load conditions.

6.3 Blower Maintenance

1. After electrical connections are completed, start motor briefly to determine the direction of wheel rotation. If necessary to reverse. The rotation, follow instructions given on the motor nameplate or terminal box cover.
2. Follow motor manufacturer's instructions for motor lubrication. Remove excess lubricant.
3. Follow Replacement Parts Manual for blower bearing lubrication.
4. Check wiring to make sure it is secure and well insulated.

6.4 Blower Troubleshooting Chart

Symptom	Possible Cause(s)	Corrective Action
Excessive noise and/or vibration	<ol style="list-style-type: none"> 1. Foreign object 2. Wheel rubbing on housing 3. Loose wheel or sheave on shaft 4. Motor or blower not secure 5. Belt(s) too loose/too tight 6. Worn belt(s) 7. Mismatched belt(s) 8. Loose or worn bearings 9. Bearing or drive alignment 10. Accumulation of material on wheel 11. Motor out of balance 12. Wheel out of balance 13. Sheaves eccentric or out of balance 	<ol style="list-style-type: none"> 1. Remove 2. Center the wheel 3. Tighten all set screws 4. Tighten Mounting 5. Adjust Tension 6. Replace 7. Replace 8. Replace 9. Realign 10. Clean 11. Replace 12. Replace or Re-balance 13. Replace
Insufficient air flow	<ol style="list-style-type: none"> 1. Blower speed too low 2. Dampers or registers closed 3. Dirty or clogged filters 4. Leaks in duct work 5. Elbows, cabinet walls, or other obstructions 6. Belt slippage 	<ol style="list-style-type: none"> 1. Check for correct drives 2. Open 3. Clean or replace 4. Repair 5. Correct 6. Adjust or replace
Too much air flow	<ol style="list-style-type: none"> 1. Blower speed too high 2. Filter(s) not in place 	<ol style="list-style-type: none"> 1. Check for correct drives 2. Install filter(s)
Unit fails to operate	<ol style="list-style-type: none"> 1. Blown fuse or open circuit breaker 2. Broken fan belt 3. Defective motor and/or capacitor 	<ol style="list-style-type: none"> 1. Replace or reset 2. Replace 3. Replace
Motor overloads or overheats	<ol style="list-style-type: none"> 1. Blower speed too high or motor horsepower too low 2. System static pressure too low 3. Shorted windings in motor 	<ol style="list-style-type: none"> 1. See Specifications for correct drives and HP 2. Check static pressure and correct system 3. Replace

APPENDIX 1 - MAINTENANCE RECORD

Diversitech Inc. authorizes this page to be photocopied or otherwise reproduced as needed for management of maintenance records.

MANUFACTURER:	DIVERSITECH INC.	MODEL N°	AMBIENT AIR CLEANER	SERIAL N°	
SERVICE LOCATION:				CONTROL N°	

Date	Description of Service	Serviced By	Location	Comments

Only use manufacturer approved replacement parts on this unit.

NOTES

NOTES

NOTES

TERMS AND CONDITIONS TO SALES ORDERS

1. INTERPRETATION

- 1.1. All references to “we” herein mean Diversitech Equipment and Sales (1984) Ltd.
- 1.2. All references to “you” herein mean:
 - (a) the “Customer” referred to herein and in the Sales Order joining these presents (such Sales Order together with any amendments, supplements and additional agreements related thereto and all annexes and schedules in respect thereof, collectively the “**Sales Order**”); and
 - (b) any affiliates and any party related, whether directly or indirectly, to such “Customer”.

2. LIMITED WARRANTY AND LIABILITY

- 2.1. All units and equipment sold by us to you (collectively “**Units**”) pursuant to the Sales Order are warranted to be free from defects in material for a period of **2 years from the date of purchase** (the “**Warranty Period**”).
- 2.2. We will repair or replace, at our discretion, any defective parts that fail during the Warranty Period, returned to the manufacturer’s plant with freight prepaid. This warranty is limited to replacement parts ONLY, subject to on-site or in- house evaluation of defective materials and does not apply to any personal liability or property loss that occurs due to the use or installation of this equipment.
- 2.3. We expressly exclude all warranties whatsoever, other than those included in Section 2.1 hereof, express or implied, legal or conventional, including, without limitation, any and all warranties of quality, merchantability and fitness for a particular purpose.
- 2.4. To the extent that any Units are integrated with any products, equipment, units, connections and/or systems of a third-party (“**Third-Party Products**”), we hereby expressly exclude all of the following warranties, express or implied, namely:
 - (a) warranty against defects of any kind (latent or apparent), fitness for purpose, merchantability or functionality to the extent of any such Third-Party Products; and
 - (b) any warranty against any defects or problems of any kind, whether latent or apparent, in respect of Units or a Third-Party Product, caused or arising directly or indirectly as a result of the integration with or use of Units in connection with any Third-Party Product.
- 2.5. You hereby expressly waive and renounce to any and all claims against us relating to loss of profits, loss of business or goodwill, interruption of business and all indirect, special, incidental or consequential damages of any kind whether arising from or in connection with the Sales Order or from the use of Units, however caused, and whether in the nature of breach of obligations, breach of warranty, repudiation of contract, tort, negligence (save in the event of gross negligence or intentional fault) or otherwise. Accordingly, save in the event of gross negligence or intentional fault, we shall have no liability whatsoever towards you under this agreement for any losses or damages, direct or indirect, consequential, exemplary, incidental or otherwise, regardless of whether we received advanced notice or were advised of the possibility of such claim, loss or damage.
- 2.6. You are solely responsible for determining if Units fit your particular purpose and are suitable for your designated process, application, fitment, tooling, set-up and uses(s).

3. FREIGHT CLAIMS

- 3.1. Shipments must be inspected by you upon arrival. All Units are sold ex-plant. Therefore, it is the receiver’s responsibility to file any freight claims with the carrier for obvious or concealed damages. Damaged shipments must be refused at the time of receipt.

4. RETURN MATERIAL POLICY

- 4.1. Prior to the return of material, for whatever reason, a return merchandise authorization number (“**RMA#**”) is required from our customer service department. This procedure is necessary for proper control and handling of returned materials. Call **1-800-361-3733** or email **support@diversitech.ca** to obtain a RMA #. All material must be returned prepaid. Credit will be given for returns for warranty repair or replacement. Freight collect shipments will not be accepted. It is the shipper’s responsibility to ensure that material being returned to us is adequately packaged for shipment in order to prevent damages.

5. FEES AND CANCELLATION CHARGES

5.1. You will be responsible for any additional charges and fees not expressly included in the Sales Order, including, without limitation, any fees or charges relating to installation, service calls, consulting, installation, customization, "right-sizing", engineering, maintenance and/or repair. For greater certainty, unless expressly provided in the Sales Order, we do not provide you with any form of service with respect to Units, including, without limitation, installation, repair and maintenance services.

5.2. In the event that you:

- (a) cancel the Sales Order at any time whatsoever, including, without limitation, prior to shipment;
- (b) refuse to honour the Sales Order; or
- (c) fail to take possession of any Units for any reason whatsoever,

you will be responsible for reimbursement to us of any and all costs, expenses and charges we have incurred to date.

5.3. In the event that:

- (a) the Sales Order is for a customized product, including, without limitation, any custom engineered product; and
- (b) an event set forth in Section 5.2 hereof occurs,

you will be responsible for payment of the entire amount of the Sales Order in addition to the reimbursement set forth in Section 5.2 hereof.

6. JURISDICTION AND ATTORNMENT

6.1. The interpretation, validity and enforcement of these presents and the Sales Order shall be subject to and governed by the laws of the Province of Quebec and the laws of Canada applicable therein.

6.2. The parties hereto expressly submit, attorn and consent to the exclusive jurisdiction of the appropriate Court for the District of Montreal, Province of Quebec, with respect to any controversy arising out of or relating to these presents and the Sales Order, or any supplement hereto or to any transactions in connection therewith. To the extent permitted by applicable law, you irrevocably waive any objection (including any claim of inconvenient forum) that you may now or hereafter have to the venue of any legal proceeding arising out of or relating to these presents and the Sales Order in such courts.

7. GENERAL

7.1. If any provision of these presents or the Sales Order shall be held to be invalid, illegal or unenforceable, the validity, legality and enforceability of the remaining provisions shall in no way be affected or impaired thereby.

7.2. These presents and the Sales Order shall be binding upon and inure to the benefit of the parties' respective successors and assigns.

7.3. The parties hereto acknowledge that they have requested and are satisfied that the foregoing as well as the Sales Order and all notices, actions and legal proceedings be drawn up in the English language. / Les parties à cette convention reconnaissent qu'elles ont exigé que ce qui précède ainsi que le « Sales Order » et tous avis, actions ou procédures légales soient rédigés et exécutés en anglais et s'en déclarent satisfaites.

For full product support, visit our website;
<https://bit.ly/2JEcj2B>



Scan above on mobile



An Absolent
Group Company



1200 55th Avenue
Montreal, Quebec H8T 3J8
Email: info@diversitech.ca